



OPERATION MANUAL



IMPORTANT

- Before using this product, read this Manual carefully to understand the contents herein stated
- After reading this Manual, be sure to keep it near the product or in a convenient place for easy reference when necessary

ON-TARGET

OWNER'S MANUAL

SEGA AMUSEMENTS INTERNATIONAL LTD.

42 Barwell Business Park, Leatherhead Road
Chessington, Surrey
KT9 2NY
United Kingdom

Telephone: +44 (0) 208 391 8090 Facsimile: +44 (0) 208 391 8099
Email: sales@segaarcade.com Web: <http://www.segaarcade.com>

© Kaizen Entertainment

Errors & Omissions Excepted (E&OE)

BEFORE USING THE PRODUCT, BE SURE TO READ THE FOLLOWING:

TO MAINTAIN SAFETY:

To ensure the safe operation of this product, be sure to read the following before usage:

The following instructions are intended for the users, operators and the personnel in charge of the operation of the product. After carefully reading and sufficiently understanding the warning displays and cautions, handle the product appropriately. Be sure to keep this manual close to the product or in a convenient place for future reference.

Herein, explanations which require special attention are enclosed with dual lines. Depending on the potentially hazardous degrees, the terms of "**DANGER**", "**WARNING**", "**CAUTION**", etc. are used.

Be sure to understand the contents of the displays before reading the text.

PICTOGRAPHS AND DEFINITIONS

 **DANGER** Indicates that mishandling the product by disregarding this pictograph will cause severe injury or death.

 **WARNING** Indicates that mishandling the product by disregarding this warning will cause a potentially hazardous situation which can result in death or serious injury.

 **CAUTION** Indicates that mishandling the product by disregarding this caution will cause a slight hazardous situation which can result in personal injury and/or material damage.

For the safe usage of the product, the following pictographs are used:



Indicates "**HANDLE WITH CARE.**" In order to protect the human body and equipment, this display is attached to places where the instruction manual should be referred to



Indicates a "**protective earth terminal.**" Before operating the equipment, be sure to connect it to the ground (this step may be omitted for products in which a power cable with earth is used)

- **Perform work in accordance with the instructions herein stated:**
Instructions for work are explained by paying attention to the aspect of accident prevention. Failing to perform work as per the instructions can cause accidents. In the case where only those who have technical expertise should perform the work to avoid hazardous situation, the instructions herein state that the site maintenance personnel should perform such work
- **Be sure to turn off the power before working on the machine:**
To prevent an electric shock, be sure to turn off the power and unplug the power cable before carrying out any work that requires direct contact with the interior of the product. If the work is to be performed in the power-on status, the instruction manual herein always states to that effect
- **Be sure to ground the earth terminal (not required in the case where a power cable with earth is used):**
This product is equipped with the earth terminal. When installing the product, connect the earth terminal to the "accurately grounded indoor earth terminal" by using an earth wire. Unless the product is grounded appropriately, the user can be subject to an electric shock. After performing repair, etc. for the control equipment, ensure that the earth wire is firmly connected to the control equipment
- **Ensure that the power supply used is equipped with an earth leakage breaker:**
Using a power supply which is not equipped with the earth leakage breaker can cause a fire when earth leakage occurs
- **Be sure to use fuses which meet the specified rating (only for the machines which use fuses):**
Using fuses that exceed the specified rating can cause a fire and an electric shock

- **Specification changes (removal of equipment, conversions and additions) not designated by SEGA are not allowed:**
The parts of the product include warning labels for safety, covers for personal protection, etc. It is very hazardous to operate the product by removing parts and/or modifying the circuits. Should doors, lids and protective parts be damaged or lost, refrain from operating the product, and contact where the product was purchased from or the office herein stated.
SEGA shall not be held responsible for any accidents or compensation for damage to a third party resulting from the specifications not designated by SEGA
 - **Ensure that the product meets the requirements of appropriate electrical specifications:**
Before installing the product, check for electrical specifications. Ensure that the product is compatible with the power supply voltage and frequency requirements of the location. Using any electrical specifications different from the designated specifications can cause a fire and an electric shock
 - **Install and operate the product in places where appropriate lighting is available, allowing warning labels to be clearly read:**
To ensure safety for the customers, labels and printed instructions describing potentially hazardous situations are applied to places where accidents can be caused. Ensure that where the product is operated has sufficient lighting allowing the warnings to be read. If any label is peeled off, apply it again immediately. Please place an order with where the product was purchased from or the office herein stated
 - **When handling the monitor, take considerable care (applies only to products with monitors):**
Some of the monitor parts are subject to high tension voltage. Even after turning off the power, some portions are still subject to high tension voltage. Monitor repair and replacement should be performed only by those technical personnel who have knowledge of electricity and technical expertise
 - **Be sure to adjust the monitor properly (applies only to products with monitors):**
Do not operate the product leaving on-screen flickering or blurring as it is. Using the product with the monitor not properly adjusted may cause dizziness or a headache to an operator, a player, or customer
 - **When transporting or reselling this product, be sure to attach this manual to the product**
- * *In the case where commercially available monitors and printers are used in this product, only the contents relating to this product are explained herein. Some commercially available equipment has functions and reactions not stated in this Manual. Read this Manual together with the specific instruction manual of such equipment*
- * *Descriptions herein contained may be subject to improvement changes without notice*
- * *The contents described herein are fully prepared with due care. However, should any question arise or errors be found, please contact SEGA*

INSPECTIONS IMMEDIATELY AFTER TRANSPORTING THE PRODUCT TO THE LOCATION

Normally, at the time of shipment, SEGA products are in a status allowing for usage immediately after transporting to the location. Nevertheless, an irregular situation may occur during transportation. Before turning on the power, check the following points to ensure that the product has been transported in a satisfactory status:

- Are there any dented portions or defects (cuts, etc.) on the external surfaces of the cabinet?
- Are castors and adjusters damaged?
- Do the power supply voltage and frequency requirements meet with those of the location?
- Are all wiring connectors correctly and securely connected? Unless connected in the correct way, connector connections can not be made accurately. Do not insert connectors forcibly.
- Do power cables have cuts or dents?
- Are all accessories available?
- Can all doors and lids be opened with the accessory keys? Can doors and lids be firmly closed?

INTRODUCTION

This Manual is intended to provide detailed descriptions together with all necessary information covering the general operation of electronic assemblies, electromechanical, servicing control, spare parts, etc. for the product:

"On-Target"

This Manual is intended for the owners and personnel managers in charge of operation of this product. Operate the product after carefully reading and sufficiently understanding the instructions.

In the unlikely event that the product does not function correctly, **DO NOT** allow anyone other than a technician to touch the internal system. Turn off the power to the machine, making sure to unplug the electrical cord from the outlet, and contact the office listed below or the point-of-purchase for this product.

Use of this product is unlikely to cause physical injuries or damage to property. However, points that require special attention are indicated by bold text, the words "**STOP**", "**IMPORTANT**", "**WARNING**", or "**CAUTION**" and the symbols below.

IMPORTANT!

Indicates important information that, if ignored, may result in the mishandling of the product and cause faulty operation or damage to the product

WARNING **CAUTION**

Indicates a warning or caution that, if ignored, may result in the mishandling of the product and cause faulty operation or damage to the product

Sega Amusements International Limited



42 Barwell Business Park, Leatherhead Road
Chessington
Surrey, KT9 2NY
United Kingdom

European Sales:	+44 (0)208 391 8090	Email:	sales@segaarcade.com
USA Sales:	+00 (1) 224 265 4287	Email:	sales@segaarcade.com
STS (Spares):	+44 (0) 208 391 8060 (Option 1)	Email:	stssales@segaarcade.com
Tech Support:	+44 (0)208 391 8060 (Option 2)	Email:	technical@segaarcade.com
Prize & Merchandise:	+44 (0)208 391 8060 (Option 1)	Email:	segaprize@segaarcade.com

Web: <https://segaarcade.com/>

SPECIFICATIONS

Standard Cabinet

Machine Dimensions:	2.35m (92.5in) [Width] x 3.14m (123.6in) [Depth]
Machine Height:	2.6m (102.4in) (Installed)
Machine Weight:	1000kg Approx (Installed) (2204lbs)
Power, maximum current:	-5000w- (3 x Power Inlet)
Rating:	110/240~VAC @ 50/60Hz
Fuse Rating:	Game = 864W (7.85A/3.92A) Compressor 1 = 1680W (15.27A/7.63A) Compressor 2 = 1680W (15.27A/7.63A)
	3x Power inlet = 19.2A @230V~ / 41.8A @ 110V~

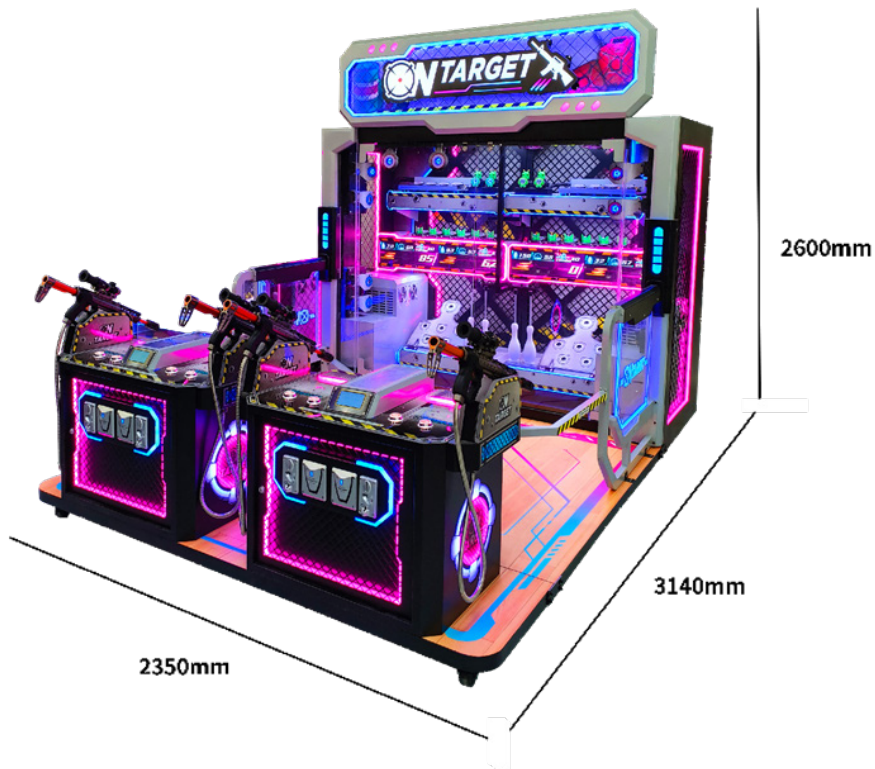

1. Operating Voltage: AC 220V - 240V, 50/60 Hz or AC110V±5%, 50/60 Hz
2. Power: 4600W (Average) 5000W (MAX)
3. Dimensions: W2350 × L3140 × H 2600 (mm)
4. Weight: 1000Kgs
5. Operating Environment: Temperature (indoors): 0 degrees celsius ~ 35 degrees celsius; Humidity: ≤90%
6. Atmospheric pressure: 86Pa~106Pa.

The game operates 3 separate power inlets all with specific power requirements.



IMPORTANT!

Procedures not described in this Manual or marked as 'to be carried out by Site Maintenance Personnel or other qualified professionals' should not be carried out by personnel without the necessary skill or technological experience. Work carried out by unqualified persons may cause serious accidents, including electrocution

Parts replacement, maintenance inspections, and troubleshooting should be carried out by site maintenance personnel or other qualified professionals. This Manual includes directions for potentially dangerous procedures which should only be carried out by professionals with the appropriate specialised knowledge.

The site maintenance personnel or other qualified professionals mentioned in this Manual are defined as follows:

Site Maintenance Personnel:

Individuals with experience in maintaining amusement equipment, vending machines, etc., working under the supervision of the owner/operator of this product to maintain machines within amusement facilities or similar premises by carrying out everyday procedures such as assembly, maintenance inspections, and replacement of units/expendable parts.

Activities to be carried out by Site Maintenance Personnel:

Amusement equipment/vending machine assembly, maintenance inspection and replacement of units/expendable parts.

Other qualified professionals:

Persons employed by amusement equipment manufacturers, or involved in design, production, testing or maintenance of amusement equipment. The individual should have either graduated from technical school or hold similar qualifications in electrical/electronics/mechanical engineering.

Activities to be carried out by other qualified professionals:

Amusement equipment/vending machine assembly, repair/adjustment of electrical/electronic/mechanical parts.

Waste of Electrical and Electronic Equipment (WEEE) Statement

The WEEE (Waste of Electrical and Electronic Equipment) directive places an obligation on all EU based manufacturers and importers of Electrical and Electronic Equipment (EEE) to ensure waste equipment is disposed of in accordance with the directive at the end of their useful life.

The symbol shown below will be placed on all products manufactured from 13th August 2005, which indicates this product must NOT be disposed of with other normal waste.

Upon purchasing any EEE from SEGA Amusements International Ltd., the user accepts responsibility to dispose of their waste equipment by arranging to return it to a designated UK collection point (AATF) or an Approved Exporter (AE) for the correct recycling of waste electrical and electronic equipment.

For more information on Approved Authorised Treatment Facilities (AATF) within the UK please consult the government website: www.gov.uk/weee

For users outside of the UK, EEE should be disposed of in accordance with the local policy on the recycling of Waste Electrical and Electronic Equipment.

Battery Recycling Statement

The EC Directive on Batteries and Accumulators (2006/66/EC) aims to minimise the impact of batteries on the environment and encourage the recovery of the materials they contain. To achieve increased collection and recycling of waste batteries, the Directive places 'producer responsibility' obligations on manufacturers and importers of portable, industrial and automotive batteries.

The symbol shown below will be on all equipment fitted with batteries from 26th September 2008 and indicates they must NOT be disposed of with other normal waste. Instead, it is the user's responsibility to dispose of used batteries by arranging to return them to a designated collection point for the correct recycling.

For more information about where you can send your waste batteries for recycling contact your local authority office.



READ BEFORE OPERATING

OPERATOR NOTICE OF LEGAL REQUIREMENTS

Applicable to operators of ticket redemption games: If you are operating a ticket redemption game, the laws and regulations on operating ticket redemption games are different in individual states, countries and territories.

The game has settings and operator options to accommodate various levels of skill and ticket payout. Local laws, regulations and codes can impact the stake, value of ticket payout and the level of skill required to win.

Not all settings and options are suitable for every jurisdiction. In some jurisdictions, ticket redemption games are prohibited.

IT IS SOLELY YOUR RESPONSIBILITY AS THE OPERATOR OF THE GAME TO:

- fully comply with laws, regulations and ticket payout value limitations in the jurisdiction where you place and offer this game to the public. (Contact your legal adviser for local advice);
- ensure that the amount of ticket payout comply with local laws (in type and value); and
- use the settings and options for play to ensure the game is operated within the local laws.

Neither the manufacturer nor distributor is responsible for any failure to operate the game in accordance with the relevant laws and regulations and has no liability for any consequences of such failure.

TABLE OF CONTENTS

INTRODUCTION	iii
HANDLING PRECAUTIONS	1
PRECAUTIONS REGARDING INSTALLATION	4
- Limitations of use	4
- Operation Area	5
PRECAUTIONS REGARDING OPERATION	7
- Before Operation	7
- Paying Attention to Customers	9
ACCESSORIES	11
ASSEMBLY AND INSTALLATION	12
- Installation Process	13
- Fixation to Site	20
PRECAUTIONS WHEN MOVING	23
- Moving the Machine	24
GAME DESCRIPTION	25
- How to Play	25
- Game Settings	26
TEST AND SERVICE DATA	27
CONTROLLER UNITS	28
TROUBLESHOOTING	30
SCHEMATIC DIAGRAMS	35

HANDLING PRECAUTIONS

When installing or inspecting the machine, be mindful of the following points and pay attention to ensure that the player can enjoy the game safely.

Noncompliance with the following points or inappropriate handling running counter to the cautionary matters herein stated can cause personal injury or damage to the machine.

WARNING

- **Before performing work, be sure to turn the power off. Performing the work without turning the power off can cause an electric shock or short circuit. In cases where work should be performed in the status of power on, this Manual always states to that effect**
- **To avoid an electric shock or short circuit, do not plug in or unplug quickly**
- **To avoid an electric shock, do not plug in or unplug with a wet hand**
- **Do not expose power cords or earth wires on the surface, (floor, passage, etc). If exposed, the power cords and earth wires are susceptible to damage. Damaged cords and wires can cause an electric shock or short circuit**
- **To avoid causing a fire or an electric shock, do not put things on or damage the power cords**
- **During or after installing the product, do not unnecessarily pull the power cord. If damaged, the power cord can cause a fire or an electric shock**
- **In the case that the power cord is damaged, ask for a replacement through where the product was purchased from or the office herein stated. Using the cord as is damaged can cause fire, an electric shock or leakage**
- **Be sure to perform grounding appropriately. Inappropriate grounding can cause an electric shock**
- **Be sure to use fuses meeting the specified rating. Using fuses exceeding the specified rating can cause a fire or an electric shock**
- **Be sure that connections such as IC Board are made properly. Insufficient insertion can cause an electric shock**
- **Specification changes, removal of equipment, conversion and/or addition, not designated by SEGA are not permitted**
- **Failure to observe this may cause a fire or an electric shock. Noncompliance with this instruction can have a bad influence upon the physical conditions of players or onlookers, or result in injury during play**
- **SEGA shall not be held responsible for damage or compensation for damage to a third party caused by specification changes not designated by SEGA**
- **Do not perform any work or change parts not listed in this Manual. Doing so may lead to an accident**
- **If you need to perform any work not listed in this Manual, request work from the office indicated in this Manual or the point of purchase, or inquires for details. Be sure to perform periodic maintenance inspections herein stated**

 **WARNING**

- Do not touch undesignated places. Touching places not designated can cause electric shock or short circuit
- Whenever any fasteners (e.g. screws, nuts) have been lost, be sure to use replacement fasteners with proper dimensions as specified in this Manual. If fasteners of any other dimensions are used, it could cause damage and/or separation of parts that result in secondary accidents
- Specification changes, removal of equipment, conversion and/or addition, not designated by SEGA are not permitted
- Failure to observe this may cause a fire or an electric shock. Noncompliance with this instruction can have a bad influence upon the physical conditions of players and onlookers, or result in injury during play
- SEGA shall not be held responsible for damage or compensation for damage to a third party caused by specification changes not designated by SEGA
- Performing work or parts replacements not described in this Manual could result in accidents. If you need to perform any work not listed in this Manual, request work from the office indicated in this Manual or the point-of-purchase, or inquires for details
- Be sure to perform periodic maintenance inspections herein stated

 **IMPORTANT!**

- For the IC board circuit inspections, only the use of a logic tester is recommended. Using a Multi-Tester or General Purpose Tester may result in damage to IC Circuits
- Static electricity from your body may damage some electronic devices on the IC board. Before handling the IC board, touch a grounded metallic surface so that the static electricity can be discharged
- Some parts are not designed or manufactured specifically for this game machine. The manufacturers may discontinue or change the specifications of such general-purpose parts. If this is the case, SEGA cannot repair or replace a failed game machine whether or not a warranty period has expired

CONCERNING THE STICKER DISPLAY

This SEGA product has stickers attached describing the product manufacture No. (Serial No.) and Electrical Specifications. It also has a Sticker describing where to contact for repair and for purchasing parts.

When inquiring about or asking for repairs, **mention the Serial No. and Name of Machine indicated on the Sticker.**

The Serial Number indicates the product register. Identical machines could have different parts depending on the date of production. Also, improvements and modifications might have been made after the publication of this Manual.

In order to ensure you order the correct parts, mention the Serial No. when contacting the applicable places.

CONCERNING WARNING DISPLAYS

This SEGA product has warning displays on stickers, labels and/or printed instructions adhered/attached to or incorporated in the places where a potentially hazardous situation could arise. The warning displays are intended for accident prevention for customers and for avoiding hazardous situations relating to maintenance and servicing work.

Some portions of the Cabinet contain high voltage and may cause accidents if touched. When performing maintenance, be very careful of the warning displays. It is especially important that any complex repair and replacement work not mentioned herein should be performed by those technical personnel who have knowledge of electricity and has technical expertise.

In order to prevent accidents, caution any customer ignoring the warnings to cease and desist immediately.

PRECAUTIONS REGARDING INSTALLATION

WARNING

- This product is an indoor game machine. Do not install it outside. Even indoors, avoid installing in places mentioned below so as not to cause fire, electric shock, injury and/or malfunction:
- Places subject to rain/water leakage or places subject to high humidity, in the proximity of an indoor swimming pool and/or shower, etc
- Places subject to direct sunlight or places subject to high temperatures, in the proximity of heating units, etc
- Places filled with inflammable gas or vicinity of highly inflammable/volatile chemicals or hazardous matter
- In dusty places or locations prone to heavy dust accumulation
- On sloped or uneven surfaces
- Places subject to any type of violent impact
- Vicinity of anti-disaster facilities such as fire exits and fire extinguishers
- Areas where the temperature exceeds the applicable temperature (ambient temperature) range of 5 to 30 degrees centigrade

LIMITATIONS OF USAGE

WARNING

- Be sure to check the Electrical Specifications. Ensure that this product is compatible with the location's power supply, voltage, and frequency requirements. A plate describing Electrical Specifications is attached to the product. Noncompliance with the Electrical Specifications can cause a fire and electric shock
- This product requires a Breaker and Earth Mechanism as part of the location facilities. Using the product without these can cause a fire and electric shock
- Ensure that the indoor wiring for the power supply is rated at 15 A or higher (AC single phase 100 V ~ 120 V area), and 7 A or higher (AC 220 V ~ 240 V area). Noncompliance with the Electrical Specifications can cause a fire and electric shock
- Be sure to use an independent power supply equipped with an Earth Leakage Breaker. Using a power supply without an Earth Leakage Breaker can cause an outbreak of fire if a power surge occurs
- Putting many loads on one electrical outlet can cause generation of heat and a fire resulting from overload
- When using an extension cord, ensure that the cord is rated at 15 A or higher (AC 100 V ~ 120 V area) and 7 A or higher (AC 220 V ~ 240 V area). Using a cord rated lower than the specified rating can cause a fire and electric shock



IMPORTANT!

- Securing a safe area for operation as described in this Manual will ensure safe operation for players and observers
- SEGA shall not be held responsible for damage or compensation for damage to a third party, resulting from the failure to observe this instruction

OPERATION AREA

WARNING

- For safe operation, use and operate this product in an area measuring at least **3.35m (131in)** in width and **4.14m (162in)** in depth when the Cabinet is installed. SEGA shall not be held responsible for damage or compensation for damage to a third party, resulting from the failure to observe this instruction
- The ceiling where this product is installed must be at least **2.6m (102in)** high. If the ceiling is too low, the heat emitted from the product may cause it to catch on fire
- Be sure to provide the sufficient space specified in this Manual. Do not allow objects to block the ventilation ports. This can cause generation of heat and a fire
- Put the Cabinets close together so that people cannot get through or provide enough space between them that people can go both ways without difficulty. If the Cabinets are installed carelessly, people may bump into each other or the Cabinets when passing between them or fall down. To prevent people from walking between them, place them 0.15 m (5.9 in) apart
- If the machine does not fit through the entryway to the installation location, do not disassemble it without first consulting the instructions. Specific tools and adjustment procedures are required to assemble and disassemble the mechanical parts
- Attempting to assemble or disassemble the machine without consulting the instructions may result in accidents during assembly/disassembly, electric shock, short circuits, and/or personal injury during operation. If the machine still does not fit through the entryway after following the procedures in this Manual, contact your retailer or the office listed in this Manual
- If the machine is still too large to fit through the entryway after following the procedures listed in this Manual, do not tip the machine on its side. Attempting to transport the machine while it is tipped on its side may cause accidents. It may also damage or warp parts of the machine, resulting in accidents during operation

⚠ WARNING

- To install this product, the entrance must be at least **2.35m (92.5in)** in width and **2.6m (102in)** in height with the Billboard
- If the entrance is too narrow, do not tilt the product carelessly. If all the product weight is put on the castors at one side only, there could be damage or deformation, causing serious accidents such as workers getting caught underneath

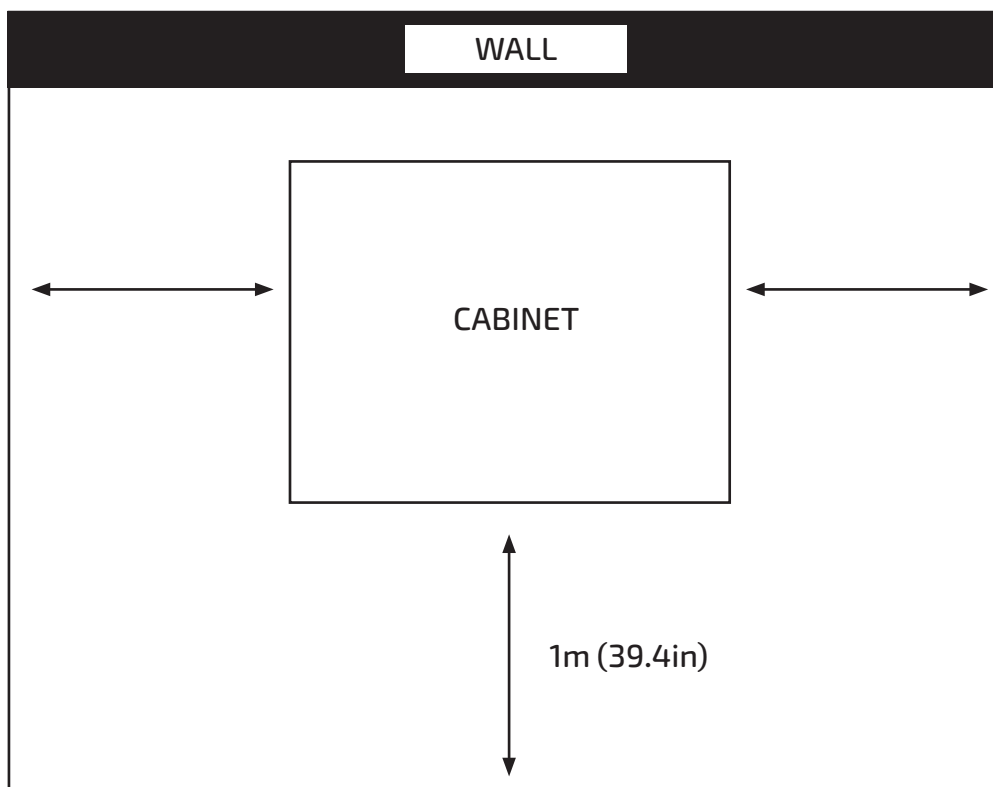

(not to scale)

PRECAUTIONS REGARDING OPERATION

To avoid injury and trouble, be sure to pay attention to the behaviour of visitors and players.

BEFORE OPERATION

WARNING

- In order to avoid accidents, check the following before starting the operation:
- To ensure maximum safety for the players and the customers, ensure that where the product is operated has sufficient lighting to allow any warnings to be read. Operation under insufficient lighting can cause bodily contact with each other, hitting accident, and/or trouble between customers
- It is suggested to ensure a space allowing the players who feel sick while playing the game to take a rest
- Check if all of the adjusters are in contact with the surface. If they are not, the Cabinet can move and cause an accident
- Do not put any heavy item on this product. Placing any heavy item on the product can cause a falling down accident or parts damage
- Do not climb on the product. Climbing on the product can cause falling down accidents. To check the top portion of the product, use a step/stepladder
- To avoid electric shock, check to see if door and cover parts are damaged or omitted
- Do not place the following items on top of or near the product or hang them from the ceiling. Doing so could result in electric shock, short circuits and/or damage to the parts:
 - Flower vases, flowerpots, cups, water tanks, cosmetics, and receptacles/containers/vessels containing chemicals and water

 **CAUTION**

- To avoid injury, be sure to provide sufficient space by considering the potentially crowded situation at the installation location. Insufficient installation space can cause contact, collisions, and/or trouble between customers
- During daily cleaning, be sure to check the surface of the Control Unit and other parts that the player touches with his/her hands for damage, cracks, or loose screws. If a player uses the machine while it is damaged, cracked, or has a loose screw, the player may become injured
- Check carefully to make sure there are no gaps in the Cabinet joints and that they are not loose. If there are gaps or looseness, players may get their hands or fingers caught, resulting in an injury
- Make sure all the doors are locked securely and they do not rattle. If the doors are not locked properly or there are gaps or rattling, players could get their fingers or hands caught
- Inspect for the following items during a trial run. If there is any type of error, use the Test Mode, etc. to resolve the problem. If you continue use with an error, it can cause an accident or irreparable parts damage:
 - Is there any strangeness in the operability of the Control Unit?
- Prepare a place where players can rest if they feel sick

PAYING ATTENTION TO CUSTOMERS

To avoid injury and trouble, be sure to constantly give careful attention to the behaviour and manner of the visitors and players.

DURING OPERATION (PAYING ATTENTION TO CUSTOMERS)

WARNING

- For safety reasons, do not allow any of the following people to play the game:
 - Those who have high blood pressure or a heart problem
 - Those who have experienced muscle convulsion or loss of consciousness when playing video games, etc
 - Those who have neck or spinal cord problems
 - Those who are intoxicated or under the influence of drugs
 - Pregnant women
 - Those who are not in good health
 - Those who do not follow the attendant's instructions
 - Those who cannot grasp the Control Unit securely because of immobility in fingers, hands or arms
 - Persons who disregard the product's warning displays
- Even players who have never been adversely affected by light stimulus might experience dizziness or headache depending on their physical condition when playing the game
- Small children are especially likely to experience these symptoms. Caution guardians of small children to keep watch over them during play
- Instruct those who feel sick during play to have a medical examination
- To avoid injury from falls and electric shocks due to spilled drinks, instruct the player not to place heavy items or drinks on the product
- To avoid electric shocks and short circuits, do not allow customers to put hands, fingers or extraneous matter in the openings of the product or small openings in and around the doors
- To avoid falls and resulting injury, immediately stop the customer from leaning against or climbing on the product, etc
- To avoid electric shock and short circuit, do not allow customers to unplug the power plug without a justifiable reason
- Instruct the guardians of small children to keep watch over their children
- Children cannot sense danger. Allowing small children to get near a player who is playing the game could result in the children being bumped, struck or knocked down

IMPORTANT!

- Diligently clean the parts that players touch directly to ensure a pleasant game playing experience
- Inspect the coin insertion slots to make sure no foreign objects have been inserted and that they have not otherwise been tampered with as this will prevent play

CAUTION

- Immediately stop such violent acts as hitting and kicking the product. Such violent acts can cause parts damage or falling down, resulting in injury due to fragments and falling down
- Persons other than the player should not be allowed to touch the controls during play. They may brush against or collide with the controls or the player, possibly resulting in accidents
- Instruct those who feel sick during play to have a medical examination
- Immediately stop users from leaning or sitting on the Control Panel. Such acts can lead to injury or damage to parts or the shape of the Cabinet
- Items such as large finger rings can cause injury to the fingers while playing. Instruct players to remove all accessories that could cause an accident before playing

ACCESSORIES

Confirm that the accessories listed in the table below are present when setting up the product. Accessories marked “Spare” are consumable items but included as spares.

ITEM NAME	SPECIFICATION	QTY
Power supply cord		3
User Manual		1
Fuse 10*38		3
Gun Microswitch		2
Microswitch Holder		1
Trigger Spring		2
Key		2
Sensor		2
Main Spring		8
Memory Card		1
Card Reader		1
8-8 Straight Joint		4
Solenoid Valve		1
Flexible Flat Cable		2
Round Light Board		1
Key Ring		5
Target Board Electromagnet		1
Cabbage Worm (with base)		5
Cross Screwdriver	3*75	1
Hex Key		1
Flat Nickel Machine 6*16		8
Complete set screws for one gun		1

WARNING

- Perform assembly work by following the procedure herein stated. Failure to comply with the instructions can cause electric shock
- Perform assembling as per this Manual. Since this is a complex machine, incorrect assembling can cause an electric shock, machine damage and/or improper functioning as per specified performance
- When assembling, more than one person is required. Depending on the assembly work, there are some cases in which working by one person alone can cause personal injury or parts damage
- Ensure that connectors are properly connected. Improper connections can cause electric shock
- Be careful not to damage the wires. Damaged wires may cause electric shock or short circuit or present a risk of fire
- This work should be carried out by site maintenance personnel or other qualified professionals. Work performed by non-technical personnel can cause a severe accident such as electric shock. Failing to comply with this instruction can cause a severe accident such as electric shock to the player during operation. If no one with proper technological expertise is available, request service from the office indicated in this document or the point of purchase so as to ensure safety
- Provide sufficient space so that assembling can be performed. Performing work in places with narrow space or low ceiling may cause an accident and assembly work to be difficult
- To perform work safely and avoid serious accident such as the Cabinet falling down, do not perform work in places where step-like grade differences, a ditch, or slope exist
- Do not leave power cords or Ground Wires exposed in areas of heavy foot traffic. Doing so may cause them to become damaged, possibly resulting in electric shock and/or short circuits. When laying wiring across the floor, always use safety covers to protect the wires. (Wiring diameter: power cable - approx. φ 8)
- Have a flashlight or another supplementary lighting unit available while working. With indoor lighting alone, the Cabinet interior may be too dark. Working without proper lighting can lead to accidents. It also hinders proper work performance
- The Cabinet has ventilation ports. Be sure not to block them. If they are blocked, heat can build up, leading to fire. This can also accelerate wearing of parts and malfunctions
- Secure ample ventilation space around the Cabinet. If heat builds up, there could be accidents associated with heat or smoke generation
- This product does not use any connectors other than those connected to and used by the Game Board when it leaves the factory. Do not needlessly connect wires to unused connectors. This could lead to overheating, generation of smoke and burn related injuries

⚠ CAUTION

- Handle molded parts with care. Excessive weight or pressure may cause them to break and the broken pieces may cause injury
- To perform the operations at height safely and accurately you must use a safe, steady footstool or stepladder. Working without this may lead to a fall and possible injury
- When attaching or removing doors or lids, be careful that your hand or finger does not get caught in anything

INSTALLATION PROCESS - MAIN CABINET

STOP IMPORTANT!

- Be careful not to damage parts surfaces. In some cases, if such surfaces are damaged, the part must be replaced; it cannot be reinforced or repaired
- Ensure to carry out the installation with a minimum of 3 people

1 Lift the top header (Marquee) up and secure using the supplied fixings

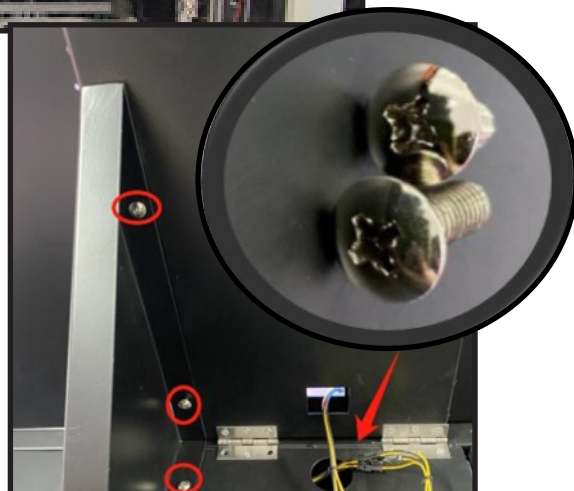

2 Remove the screws from both sides of the rear Cabinet



- 3** Place the floor section between the rear and front Cabinet sections and connect the air pipe and electrical connector

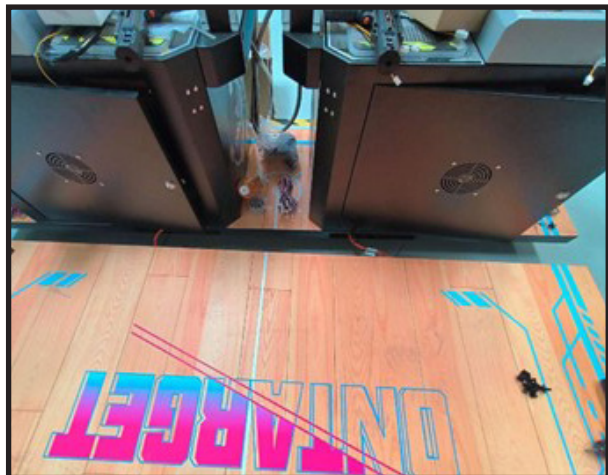

4 Connect the front and rear cabinet sections to the floor using the flat plate brackets and bolts which are already fixed to the relevant area

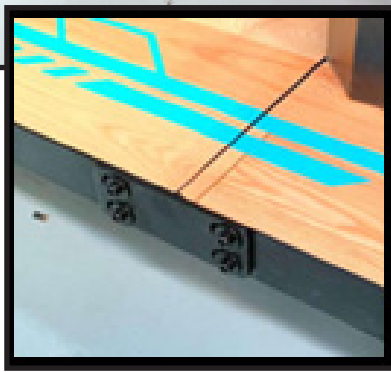
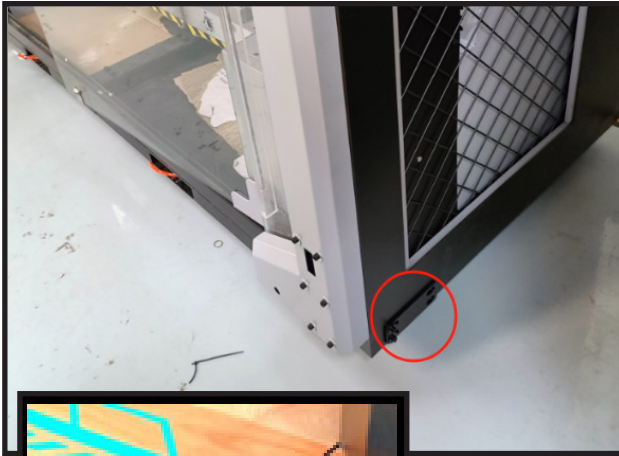

5 Locate the side panels and offer them up to the rear cabinet and connect the LED harnesses

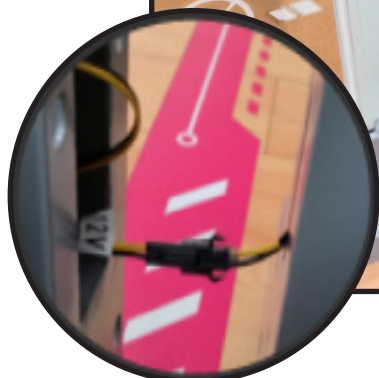

6 Secure the panels at the top and bottom using the supplied hardware that you removed in Step 2

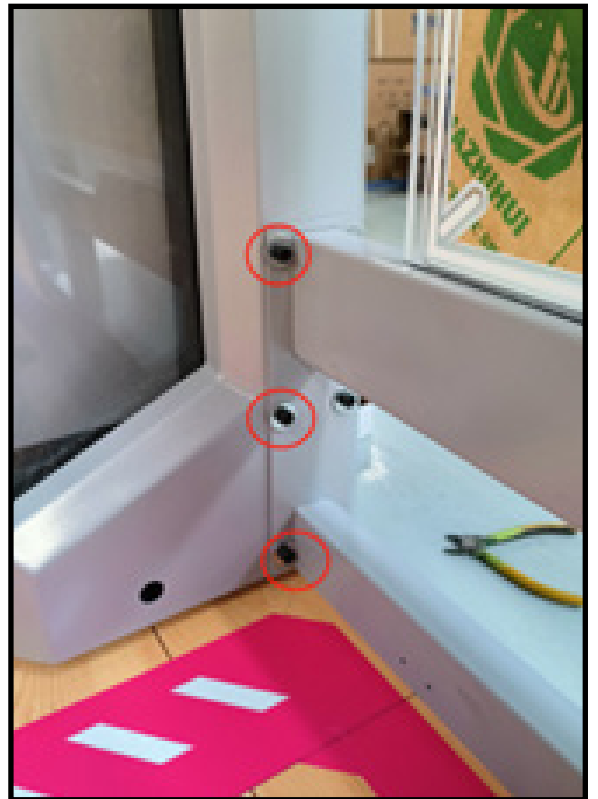
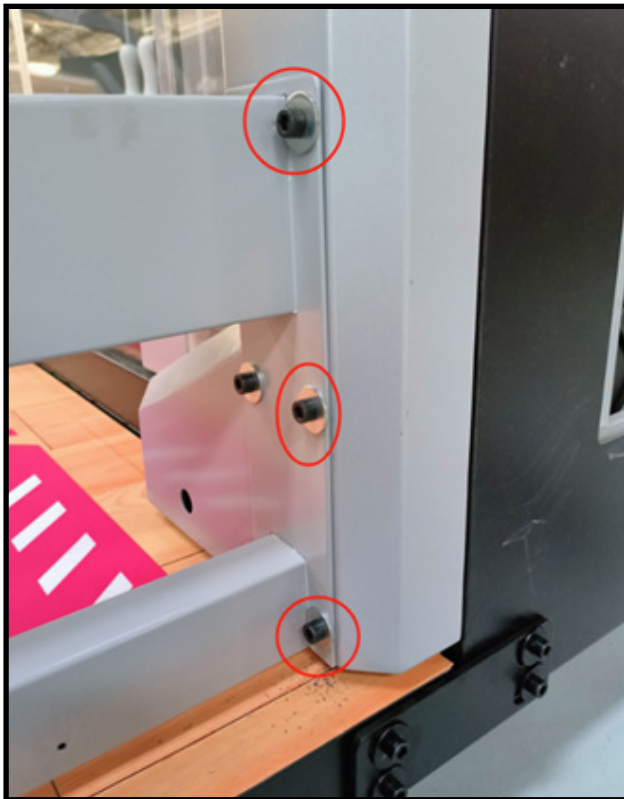

7 Secure the side panel to the floor using the supplied angle brackets



8 Install the crossbar between the side panel and controller cabinet



FIXATION TO INSTALLATION SITE

WARNING

Make sure that all the adjusters contact the floor. Otherwise the Cabinet could move, causing an accident

The product comes with castors and adjusters at multiple locations.

When the installation site has been determined, have the adjusters come in direct contact with the floor. Establish a gap of at least 5 mm between the floor and the castors and adjust the unit so that it will remain level.

- 1** Move the product to the installation site. If the product is to be installed near a wall, secure enough passageway space for players to access the seat. You must also secure a 15cm space between the back wall and the back of the cabinet for ventilation
- 2** Bring the adjusters into direct contact with the floor. Use a wrench to align the height of the adjusters until the Cabinet is perfectly level
- 3** After setting, turn adjuster nuts upwards to tighten them and secure adjuster heights

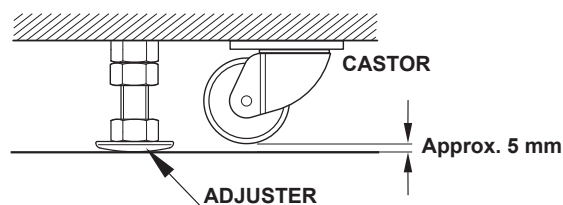
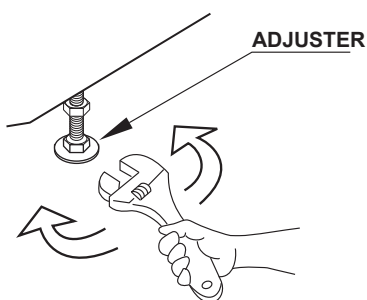

CONNECTION OF POWER AND GROUND CABLES

(Only applies where an integral earth is not present in the mains/power lead.)

WARNING

- Use the power supply equipped with an earth leakage breaker. Use of power supply without such a breaker could result in fire if there is a current leakage
- Have available a securely grounded indoor ground terminal. Without proper grounding, customers could be electrocuted and product operations might not always be stable
- Do not expose the power cord or ground wire. If these are exposed, customers could stumble over them, for instance, and easily damage them. Additionally, if these lines are damaged, there could be a risk of electrical shock or short circuit. Set these lines at locations where they will not interfere with customer traffic, or attach covers to them
- After laying out the power cord on the floor, be sure to always protect it. If the power cord is left exposed, it can easily be damaged, resulting in electrical shock
- When using the product's AC unit ground terminal, use ground wire with a circular terminal as shown in the illustration, and establish ground securely. Avoid indiscriminate grounding operations such as use of wire with only its sheath peeled off

IMPORTANT!

If grounding has been established with the ground wire inside the power cord, do not perform grounding with the AC unit ground terminal. Conversely, if the AC unit ground terminal has been used for grounding, do not establish ground with the ground wire in the power cord. Otherwise there could be faulty or erroneous operations

- 1 Confirm that the main switch is at OFF

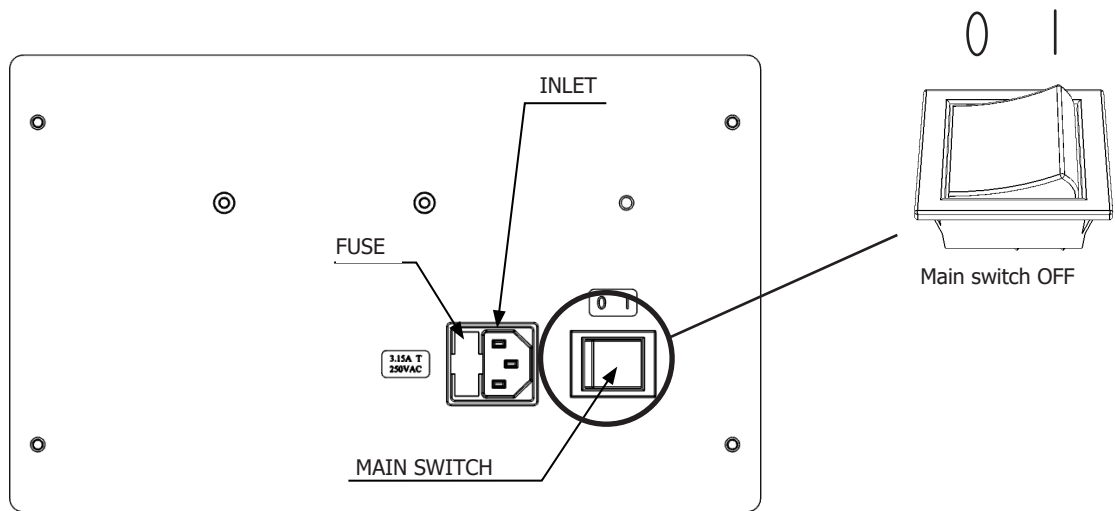

- 2 Fully insert the power cord connector on the side opposite the power plug into the AC unit inlet
- 3 Fully insert the power cord plug into the outlet

- 4 The power cord is laid out indoors. Protect the power cord by attaching wire cover to it. If ground will be established with a ground wire made available separately, lay out the ground wire indoors and have it protected

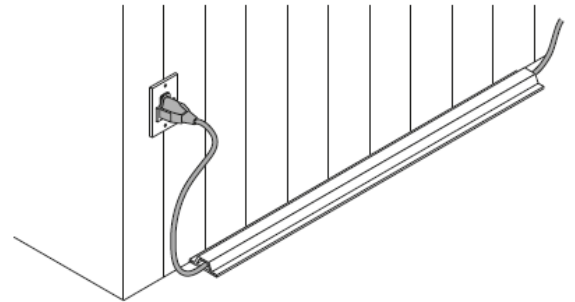

PRECAUTIONS WHEN MOVING

MOVING THE MACHINE

WARNING

- Always disconnect the power cable before moving the product. If it is moved with the power cable connected, the cable could be damaged, causing fire or electric shock
- To move the unit over the floor, pull in the adjusters and have the castors contact the floor. While moving the unit, be careful that the castors do not roll over the power cord or the ground wire. If cord or wire is damaged, there could be electrical shocks and/or short circuits
- When crossing a sloped or stepped area, disconnect the individual pieces of the Cabinet. If you tilt them while connected together, the connection points may be damaged and personnel could be injured
- When lifting the Cabinet up steps, you must hold it by any designated handles or by the bottom surface. Lifting it by any other area may lead to damage or disfiguration to that part or surrounding parts due to the weight of the Cabinet and could also lead to injury of personnel
- When tilting the Cabinet to move it across a sloped or stepped area, always use at least two people. Attempting such an operation alone can lead to accident or injury
- When moving the components separately, take care concerning the direction you push the each Cabinet section in. These elements may fall over, causing damage or an accident

CAUTION

- When moving the components, do not push any of the plastic elements or shaped parts, and do not use them to pull the components along. This may damage the parts or the surrounding parts and this could lead to accidents or injury
- When moving the separated components, be sure to push/pull each Cabinet piece lengthways. Trying to move the Cabinet any other way may cause the Cabinet to topple over



IMPORTANT!

- When moving the Cabinet, do not hold, push, or pull any Control Units. This may disfigure or damage them
- If you need to move components through a narrow or low door and the only way to get the separated components through is to turn them on their side, or if a separation method other than those described in this Manual is required, either make a request to the office listed in this document or the place of purchase to perform the operation or contact them regarding how to perform it. Carelessly turning the components onto their side or separating them in ways other than those depicted in this Manual may lead to irreparable damage
- Do not press any display screens. The screens can be easily damaged and cannot be repaired if they are, meaning complete replacement will be necessary

GAME DESCRIPTION

GAME OUTLINE

How to Play

1. Insert coin/credit to start
2. Press OK to enter the game
3. Within the specified time and the number of bullets, the number of times and scores hit the target can be counted to obtain the corresponding rewards and tickets (the specific proportion of tickets can be set in the background)
4. After hitting the set target number continuously (can be set in the background), the corresponding time combo mode will start (can be set in the background combo time)

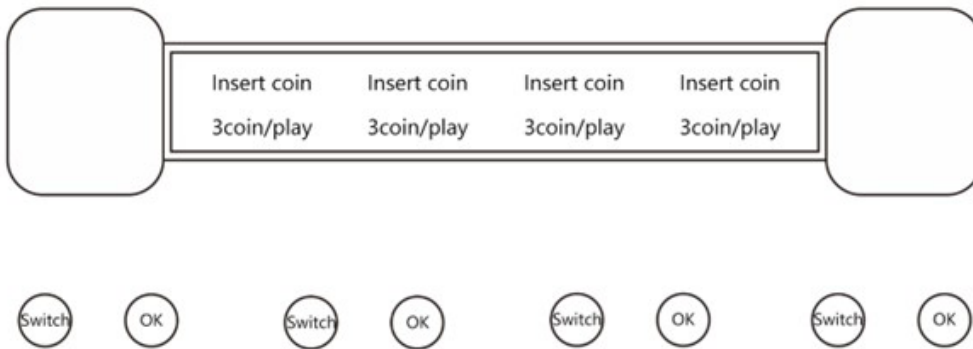

GAME SETTINGS

Option	Description
Coin Setup	Set the number of coins per game, and the number of coins needed to continue the level
Game Time for One Round	Set the time of a game. 1-240 sec
Bullet Count and Game Completion Score	Set the number of bullets given per game, and the game completion score
Ticket, Difficulty, and Combo	Set the ratio and pattern of tickets / scores, difficulty, and parameters related to combo rewards
Audio and Music Settings	Set the volume of the game's sound effects and background music, respectively, and set whether to play music when idle
Account Inquiry	Check the current day's accounts and the historical total accounts of the machine
Clear Parameters	Clear the number of coins inserted, the current remaining game time, the number of unissued tickets, the number of remaining bullets
Language	Set the current system display language
About this Machine	System information
Factory Mode	Test mode and adjustments (Laser alignment)
Factory Reset	Restore all parameters to factory default and restart the machine
Firmware Update	Update motherboard or extension board firmware

TEST AND SERVICE DATA

Operator guide (Quick Start settings)

Coin Setup Menu 1

Enter the **1. Coin Setup** menu and select **XX Coin One Game** option and use the up/down buttons to set your coins per game.

Game Time for One Round Menu 2

Select **2.Game Time for One Round** to set the game length. 50 seconds is a good game length.

Bullet Count Menu 3.1

Select **3.Bullet Count and Game Completion Score**, and then **3.1.Game Bullet Count**. Here, you can set the number of bullets the player has available per game. Generally, you do not want players to run out of bullets, as such we recommend setting the total available to double the **Game Time**.

Combo Menu 4.6/4.7

On achieving a chain of consecutive hits, the player is awarded a continuous fire bonus. This pauses the game timer for a set time and gives the player unlimited bullets and fully automatic firing. You can change the number of hits required for a combo, as well as the duration of the continuous fire bonus, by selecting **4.Ticket, Difficulty and Combo** from the menu, and then the **4.7.Combos Number Continuous Fire** and **4.8.Continuous Fire Time** settings respectively.

XX Credits to XX Tickets Menu 4.1

You can set the Score to Ticket value, displayed as **Credit to Ticket** in this menu. Each target knocked down awards 1 score. The highest score that can realistically be attained is equal to 1 score per second, most players will get scores below this number.

We recommend not setting the **Credit** value to higher than 2, as this could result in players getting much lower ticket payout than intended.

Here are some example setups. Please monitor your tickets awarded and adjust these settings as required.

Price per play, Ticket value	£1.20 play, £0.005 Ticket	£1.20 play, £0.005 Ticket	£1 play, £0.01 Ticket	£1 play, £0.01 Ticket
Approximate Tickets per game.	30% (72 Tickets)	30% (70 Tickets)	36% (36 Tickets)	30% (30 Tickets)
Game Time:	30 Seconds	50 Seconds	30 Seconds	50 Seconds
Based on Average Score:	12	20	12	20
XX Credits to XX Tickets	01 Credits to 06 Tickets	2 Credits to 7 Tickets	01 Credits to 03 Tickets	02 Credits to 03 Tickets

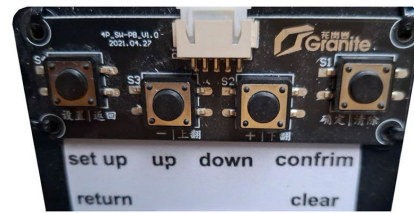

CONTROL UNIT

WARNING

- When working with the product, be sure to turn the power off. Working with the power on may cause an electric shock or short circuit
- Be careful not to damage the wires. Damaged wires may cause an electric shock, short circuit or present a risk of fire
- Do not touch any parts that are not specified in these directions. Touching unspecified locations may lead to electric shock or cause short circuits
- This work should be performed by site maintenance personnel or other skilled professionals. Work performed by non-technical personnel can cause a severe accident such as an electric shock

CAUTION

- When fastening plastic parts, be careful not to tighten screws and nuts excessively. Otherwise parts may be damaged, resulting in injuries from fragments, etc.
- Be careful not to get hand or finger caught when removing or attaching the parts
- Take care when carrying the removed Control Units. Such heavy lifting carries a risk of injury to back or shoulders

IMPORTANT!

- Handle parts inside the Control Unit very carefully. Be especially careful to avoid damage, deformation or loss of these parts. If any one of these parts is lost or defective, it can result in damages and/or faulty operations

CALIBRATING THE CONTROLLER

If the laser dot and scope are misaligned, it will result in a poor playing experience and will require calibration:

- Enter "Settings", select "Factory Mode", and select "Laser Calibration"
- After the laser turns ON, adjust the position of the magnifying cross by adjusting the knob on the magnifying glass scope
- Set the cross hair on the glass to align with the infrared dot

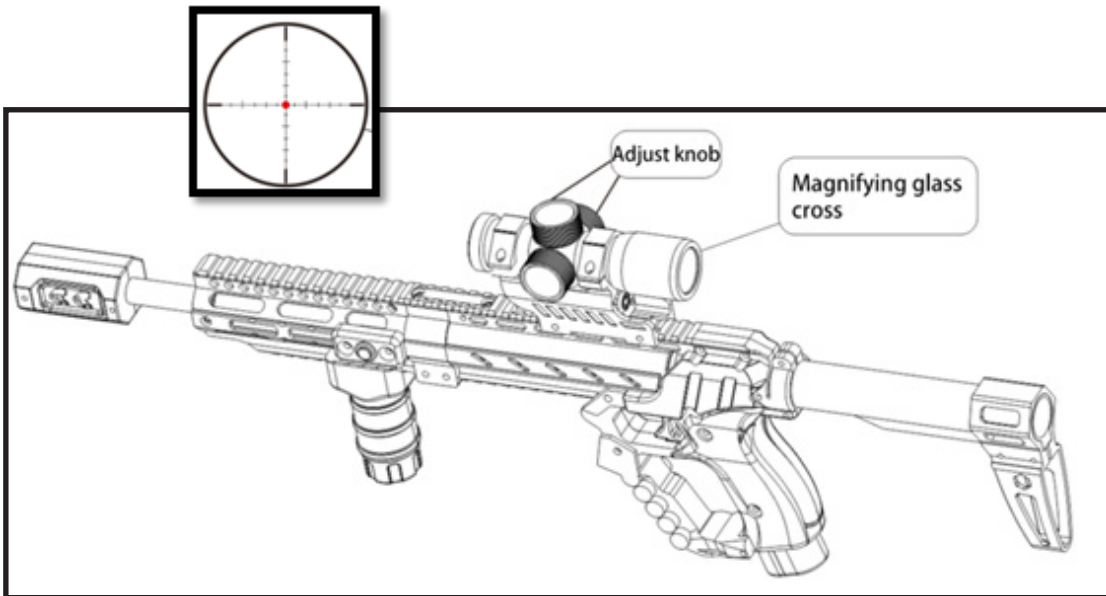

- Using a #0 flat blade screwdriver, loosen the grub screw in the top of the adjust cover
- Twist the cover off to reveal the adjustment knob
- Turn the side adjuster to calibrate left/right
- Turn the top adjuster to calibrate up/down



TROUBLESHOOTING

TROUBLESHOOTING (WHEN NO ERROR MESSAGE IS SHOWN)

WARNING

- This work should be performed by site maintenance personnel or other skilled professionals. Work performed by non-technical personnel can cause a severe accident such as an electric shock. If there are no site maintenance personnel or other skilled professionals available, turn off the power immediately and contact the office given in this Manual or from point of purchase
- When working with the product, be sure to turn the power off. Working with the power on may cause and electric shock or short circuit accident
- In order to prevent electric shock and short circuit, be sure to turn power off before performing work
- Be careful so as not to damage wirings. Damaged wiring can cause electric shock or short circuit
- After removing the cause of the functioning of the Circuit Protector (if present), reinstate the Circuit Protector. Depending on the cause of the functioning, using the Circuit Protector as is without removing the cause can cause generation of heat and fire hazard
- In the event that a problem cannot be resolved by employing the procedures listed in this Manual, be sure to request service from the office shown in this Manual or the dealer from whom the product was originally purchased. Attempts to employ procedures other than those specified in this Manual can cause electrical shock, shorting, or fire
- In the event of a problem that is not described here, be sure to contact the office shown on this Manual or the dealer from whom the product was originally purchased. Careless attempts at repair can result in electrical shock, shorting, or fire

IMPORTANT!



- If an error message is displayed, identify the cause and without delay take the appropriate countermeasures. Leaving the error unaddresses could result in a breakdown
- If a problem occurs, first inspect the connection of any wiring connectors
- Static electricity from your body may damage some electronic devices on the IC board. Before handling any IC board, touch a grounded metallic surface so that static electricity is discharged

If a problem occurs, first check to make sure that the wiring connectors are properly connected.

PROBLEM	POTENTIAL CAUSE(S) AND SOLUTIONS
Target motor overload	Check whether the corresponding target position rotates smoothly and whether there is any mechanical binding.
	Check whether the photo sensor stopper of the corresponding target position is normal or not, and whether there is any reaction after the optical sensor is covered (you can observe the indicator light of the corresponding socket of the extension board, the indicator LED is ON when it is not covered, and OFF when blocked)
	Check whether there is any burnt trace in the driving circuit of the corresponding area of the extension board, if so, it is necessary to contact the supplier/distributor for repair or replacement of the part
Target motor startup failure	Check the corresponding target board motor wires for any loose or broken parts
	Check for burn marks on the drive circuit of the corresponding area of the distributor board, if so, you need to contact your supplier/distributor for repair or replacement
Target motor turn timeout	Check whether the swing arm of the target sign is connected to the motor reliably and whether it has been decoupled
	Check whether there is any abnormality in motor's gearbox
Light strip overload	Check whether there is any damage to the corresponding extension board light strip interface, check whether there is any damage to the light strip line, whether damage or short circuit problems with the light strip
Ticket error	Check for jammed tickets
	Check the DIP switches on the ticket dispenser are set correctly (Refer to a working game and compare)
	Check the dispenser has 12v supply and drives when the button is pressed
	Check the logic level pulls LOW when tickets are due to be paid. * If pulls low and no tickets are paid, replace the dispenser ** If remains HIGH logic, check the main board in the back of player 1 controller tower *** If no logic or inconsistent level, check the wiring between the dispenser and main board in the back of player 1 controller tower

PROBLEM	POTENTIAL CAUSE
Prompt board X communication timeout or the machine has an extension board that keeps restarting automatically	Check ID (number) extension boards is crash or the power is abnormal (the green operation status indicator should be blinking slowly all the time if it is normal), and observe whether the machine can be recovered by restarting it, if not, then it is necessary to contact the supplier/distributor for help
	Check whether the board ID number is correctly set, and consult the supplier/distributor for the correct order of board ID
	Check whether the communication serial port cable of the corresponding board is loose or broken
	Check if there is any damage trace on the communication chip near the corresponding plug, if so, you need to contact the supplier/distributor for repair
Single target plate always white light	Check the corresponding round target lamp board wires for damage, and both ends of the wires to check if securely connected
All row of target plate lights are always ON white light	Check whether the corresponding extension board is operational after restarting the machine, otherwise you need to contact the supplier/distributor for repair/ replacement.
All extension board and console motherboards are automatically restarting	After the main communication cable is disconnected, the extension board and the motherboard automatically restart to try to reconnect. Check the console and the target cabinet communication cable (inside player 1 controller tower) that runs through the floor and into the target cabinet (Terminating on the right side above the compressor)
	Perform a continuity check on the communication cable from point to point
Sensor error	Check whether the sensor corresponding to the target is responsive or not, whether the wire plug is loose or not, and replace the damaged sensor or damaged wire. If the light on then sensor is blue and does not react to any gun, replace the sensor
All targets of the same extension boards report sensor error	Check all sensor connected to this extension board for damage and remove all and add one at a time back until you find the faulty sensor
	Check all the wiring interfaces of the extension board for damage, and whether there is any deviation of the wiring
	Check whether the 5V fuse of the extension board is damaged

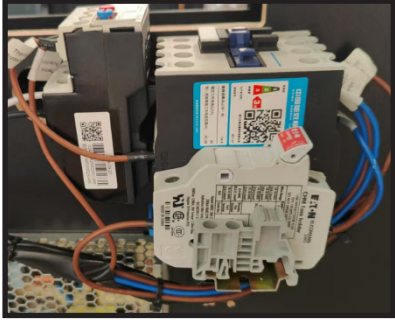
PROBLEM	POTENTIAL CAUSE
Machine audio stutters, no sound, game stutters, Console small LCD screen or repeated reboot	Check whether the memory card on the motherboard is inserted properly, and observe whether the problem is solved after replacing the memory card
	Contact your supplier/distributor for advice
No sound effects or voices for some players	Check the power of the speaker amplifier is turned on and whether the volume knob is adjusted correctly
	Check the speaker left and right channel balance knob in the center position, if not, please adjust to the center position
	Check the motherboard audio output plug is not damaged, the audio cable to there is no damage, the motherboard audio interface * J2 = 1, 2 players audio output. * J3 = 3, 4 players audio output
	If the speaker indicator light does not light up, no sound, no response to open the switch, the amp/speaker system may be damaged, please contact the supplier/distributor for help
All guns fail to fire or have no laser output	Check whether the power supply of the infrared driver circuit of the motherboard is normal
	Check wiring between main board and IR sensors
Some guns have no laser output or are hard to hit the target	Check if there is any problem with the laser line of the corresponding gun
	Check if the corresponding laser is lit - Open the menu settings -> factory setting -> laser calibration function, so that the laser is always lit
	Check wiring between the main board and IR sensor
	Replace the sensor
Some targets cannot be knocked down or are very difficult to knock down	Check if there is any damage to the corresponding round target light board cable, or whether the interface at both ends of the cable is inserted and connected securely
	Check if the target light board is damaged
	Replace sensor

PROBLEM	POTENTIAL CAUSE
Abnormal gun recoil	Check the menu settings->factory setting->gun vibration adjustment, observe if there is any error in the internal parameters, the typical value of the gun ventilation time parameter = 80ms, if not, please adjust to this parameter and retry the gun vibration (the old version of the firmware may not have this setting, skip this step).
	Check the main board valve power supply plug is loose
	Check the corresponding valve and when time you pull the trigger the LED on the valve should light. If the light does not illuminate, you need to check the corresponding line is not damaged
	If the valve light is normal, but still the recoil is intermittent or irregular, then the valve may be damaged, replace the valve and retry
Machine does not power on	Check the machine power supply socket is normal and receiving a good supply
	Check the fuse at the power supply interface of the machine in all 3 positions and replace the fuse if required. Fuse type 10*38mm
	Check the contactor is engaged
Fuse replacement	<p>There are 3 fuses in the game (2x Compressor / 1x Game) Each inlet has a contactor and fuse line. Locate the fuse module, flip open the latch and replace the fuse with the same value removed</p> <p>110v: Compressor (20A - 10x38mm type) Game (12A - 10x38mm type)</p> <p>220v: Compressor (12A - 10x38mm type) Game (6A - 10x38mm type)</p>  

Note:

The table above shows a list of possible failures and a brief solution. If problems persist further or there are additional issues which may not be listed here. Please contact your point of sale or the SEGA Service Department on the contact numbers shown at the end of this Manual.

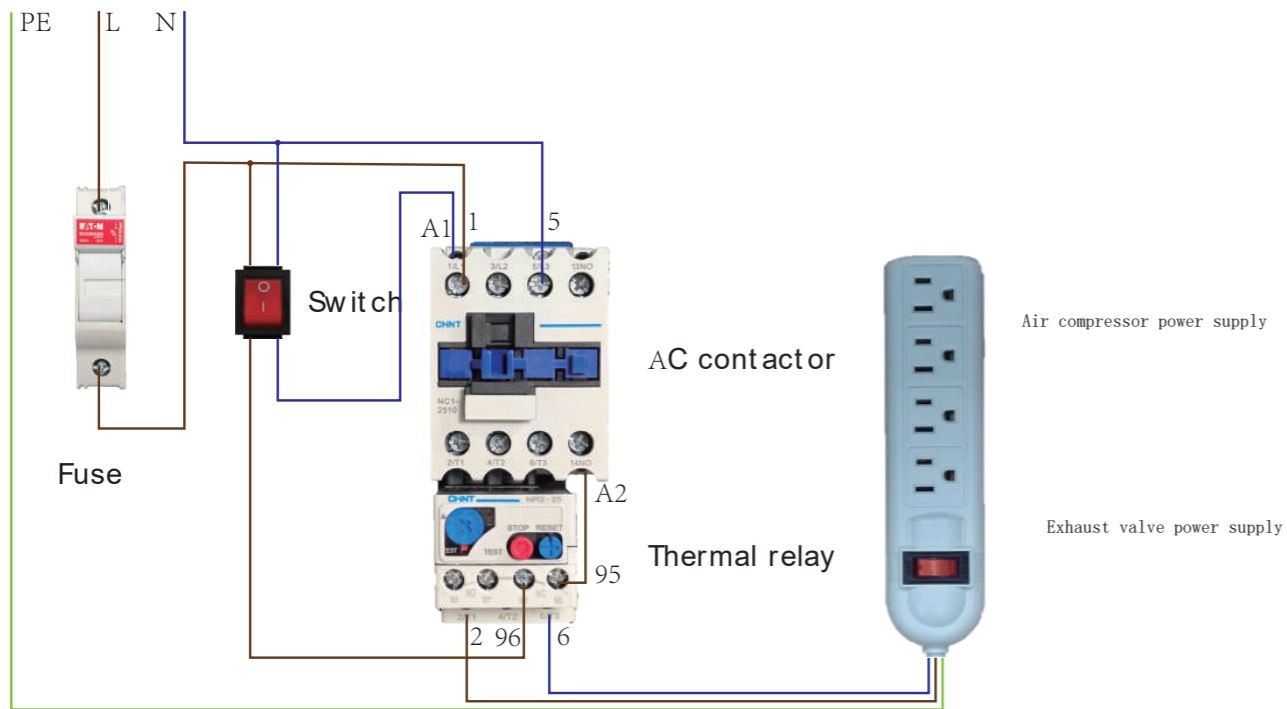
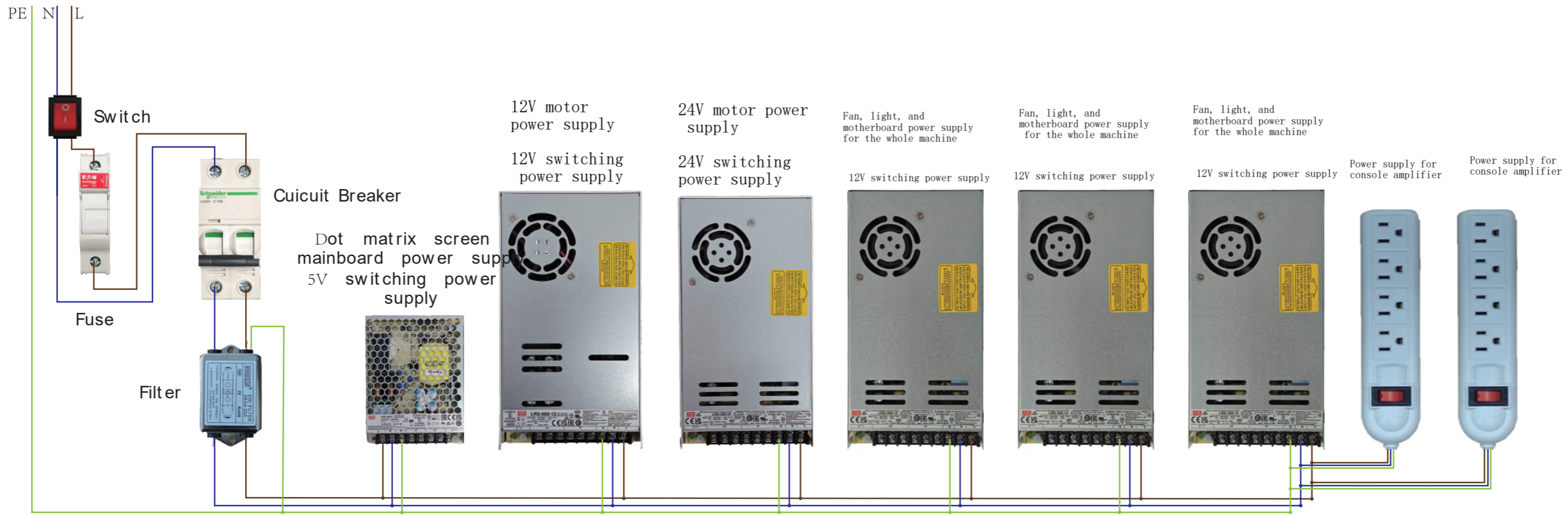

(Main Power Supply)
Shooting Gallery

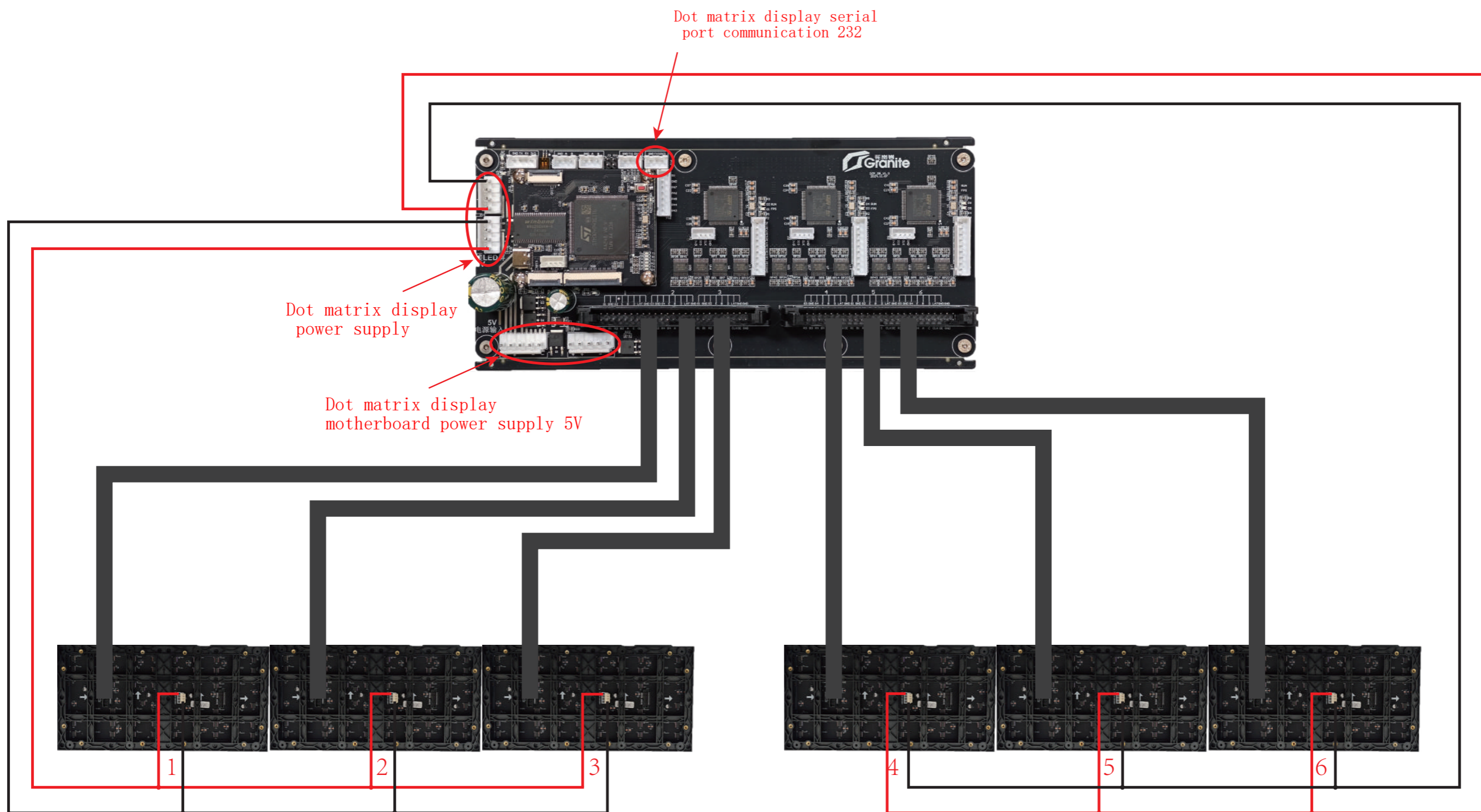

(Dot Matrix Display)
Shooting Gallery

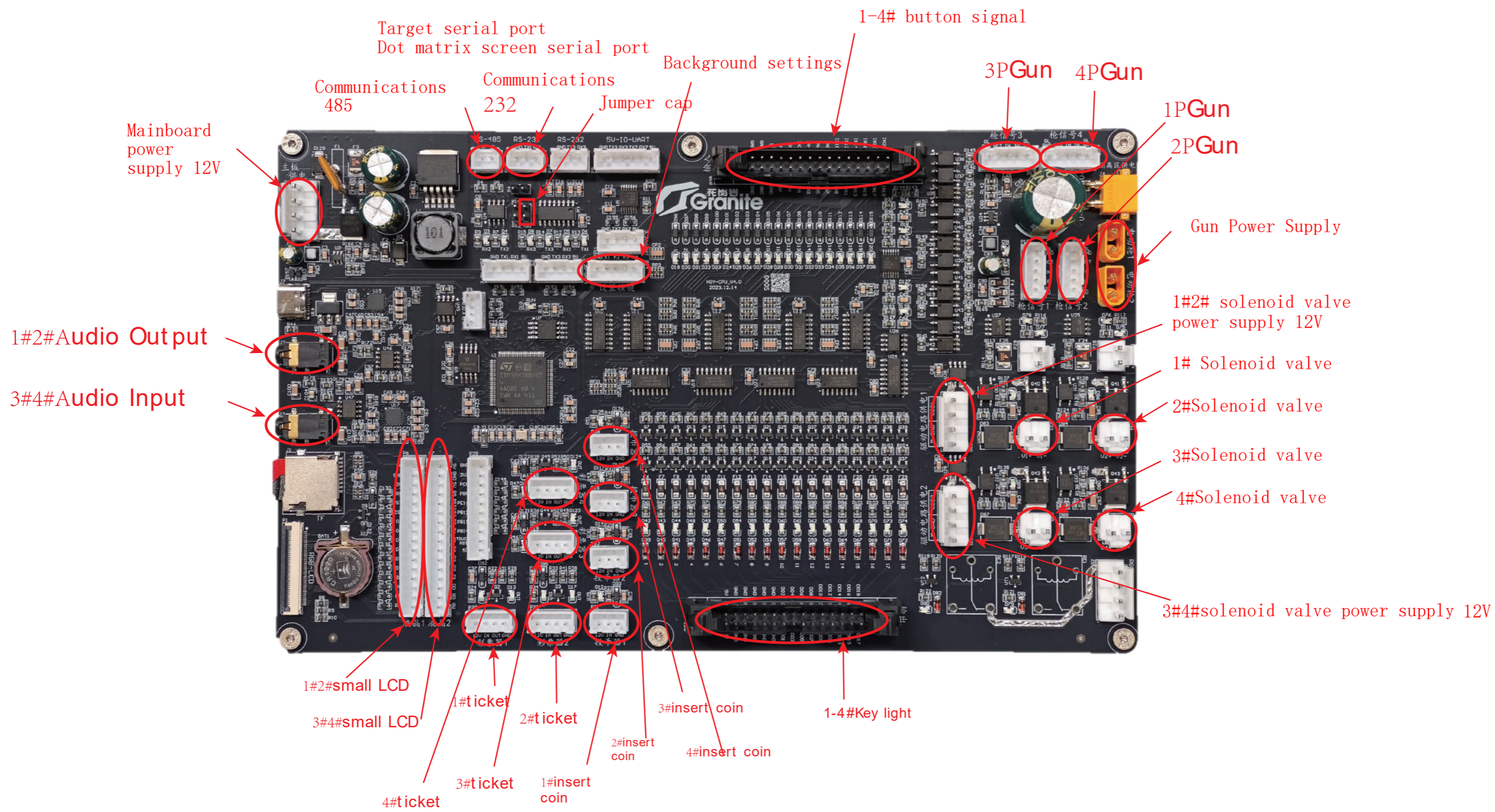

(Console Mainboard)
Shooting Gallery

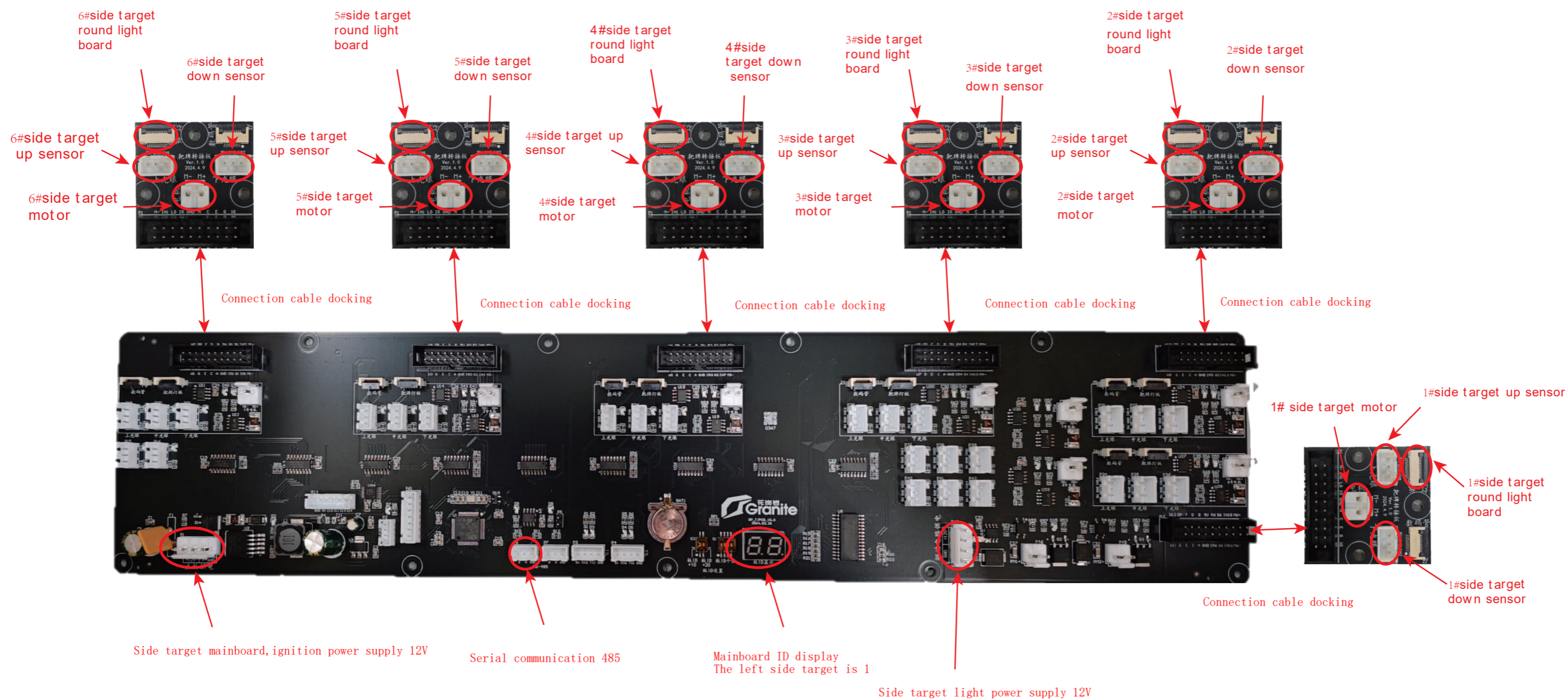

(Left Side Target) Shooting Gallery

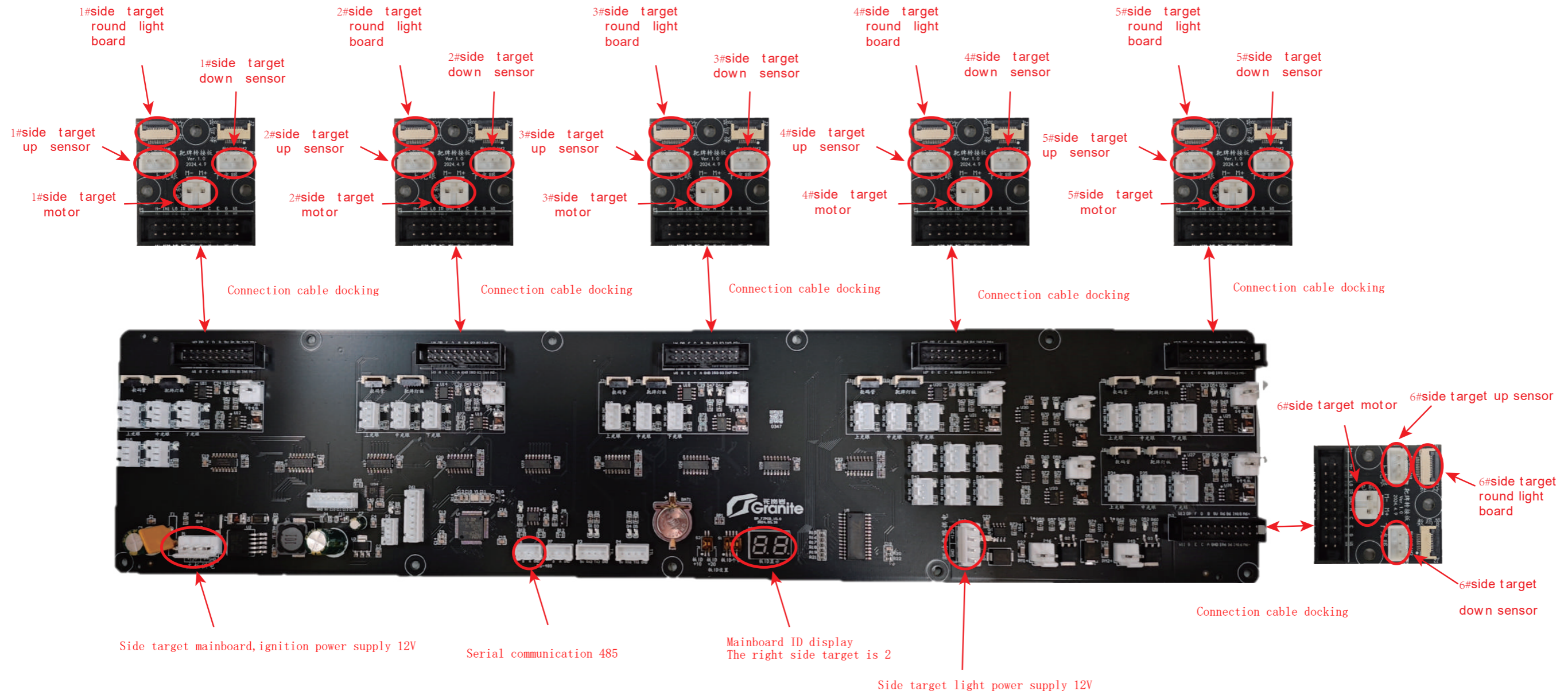

(Right Side Target)
Shooting Gallery

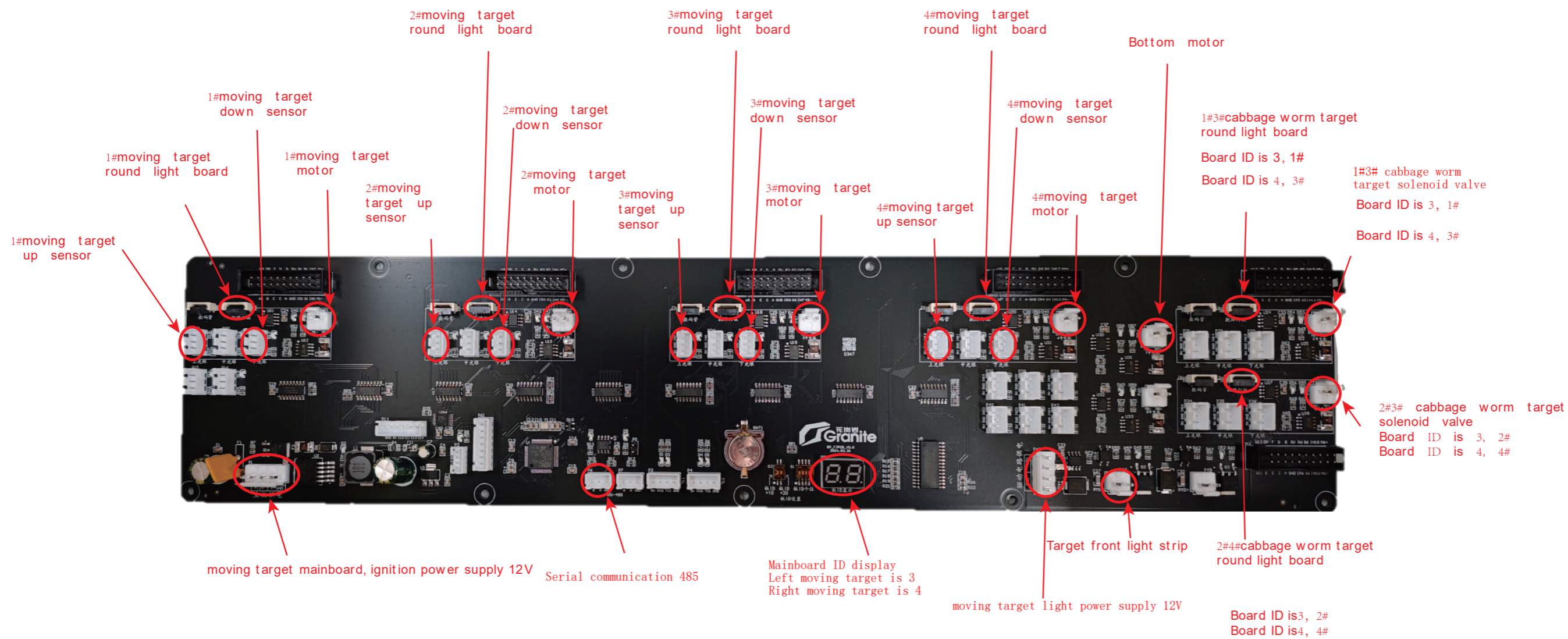

(Moving Target)
Shooting Gallery

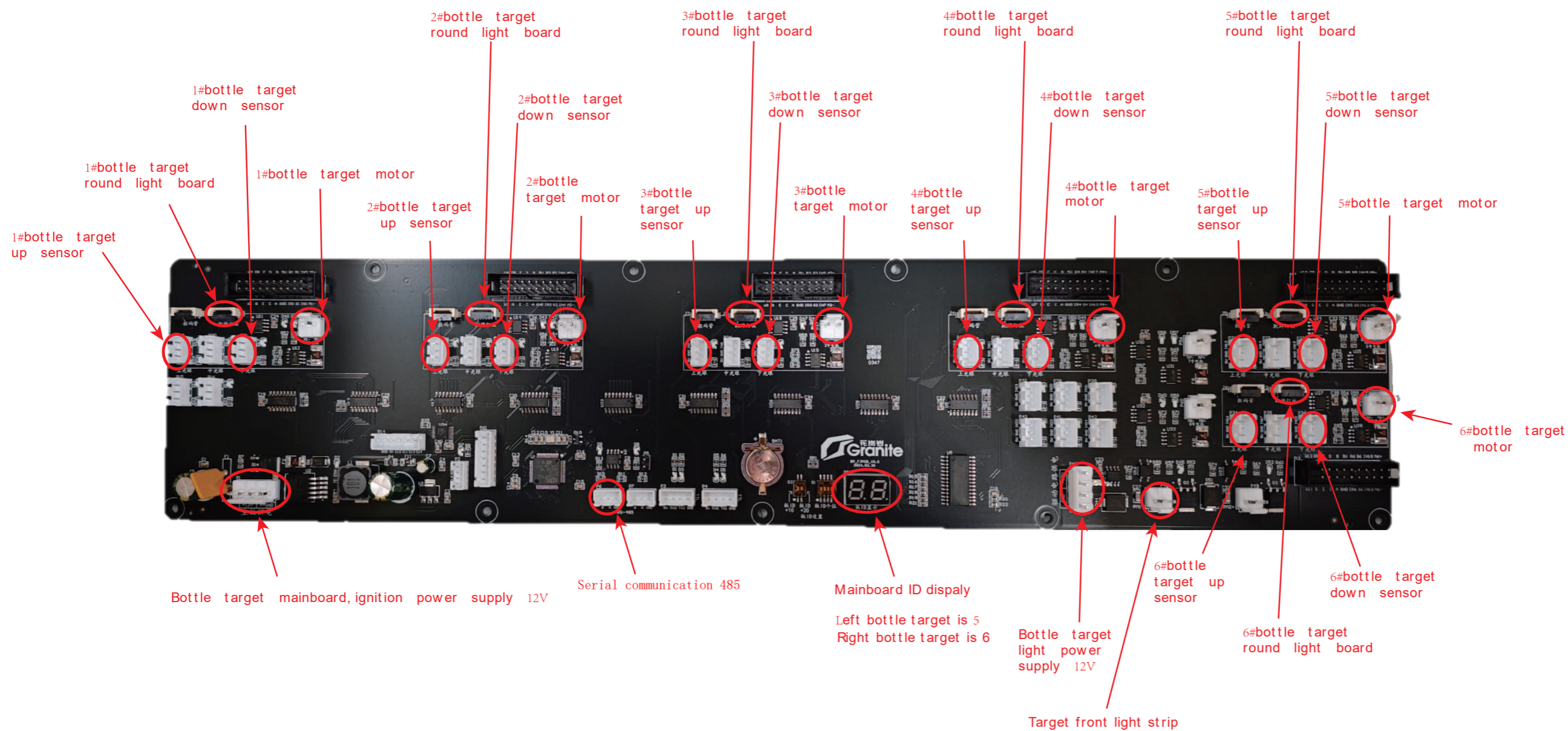

(Bottle Target)
Shooting Gallery

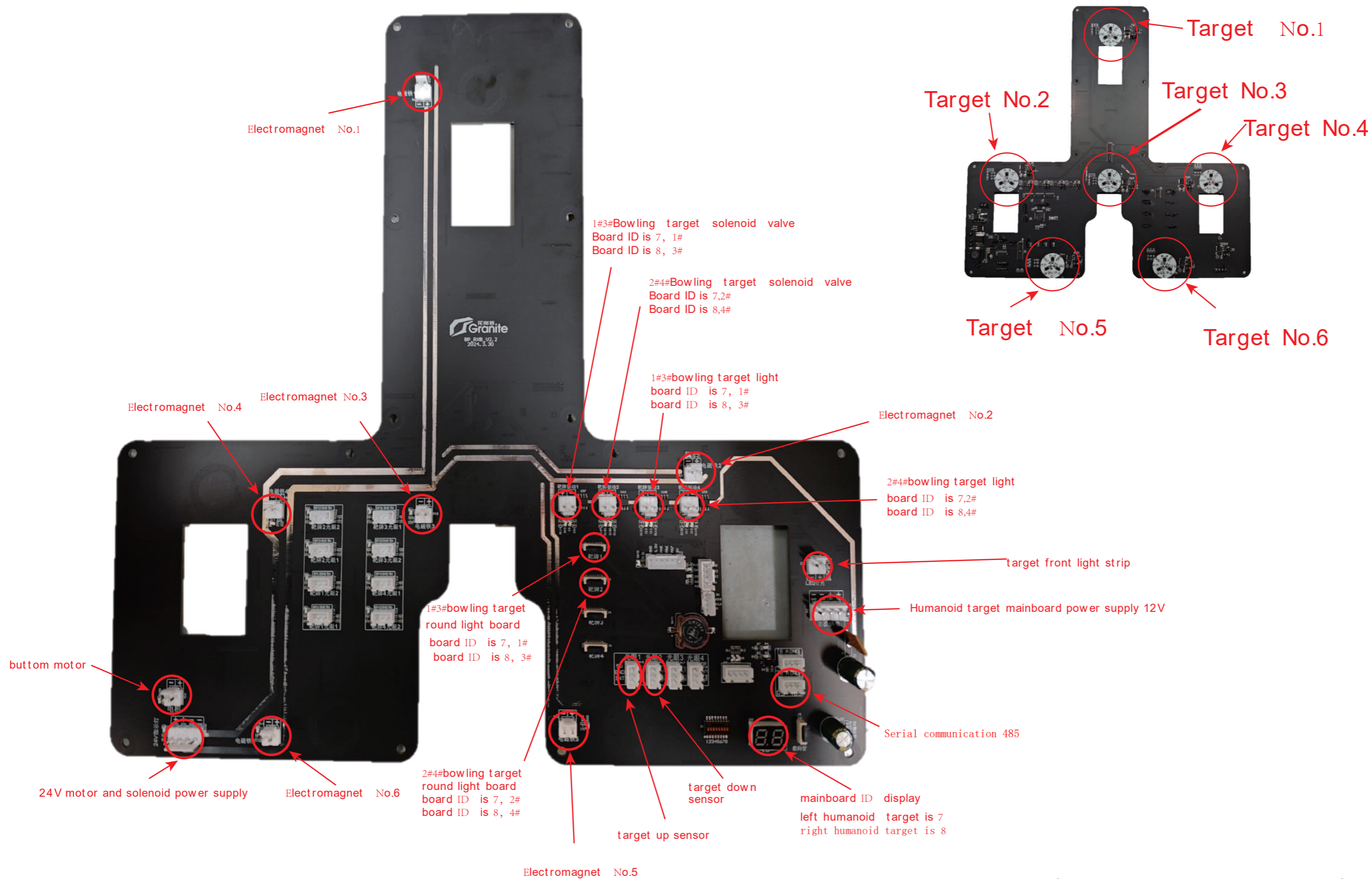

(Humanoid Target)
Shooting Gallery

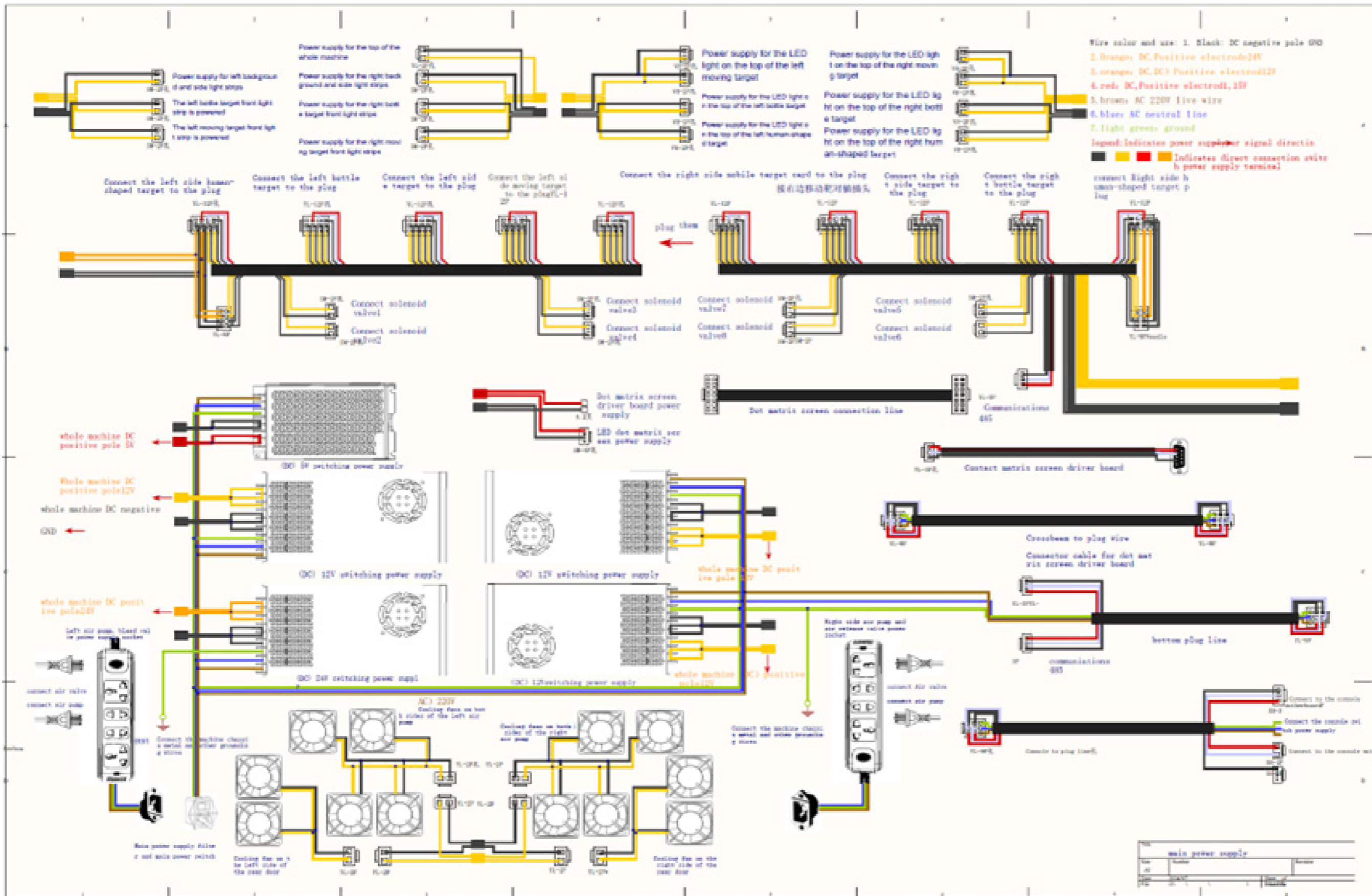

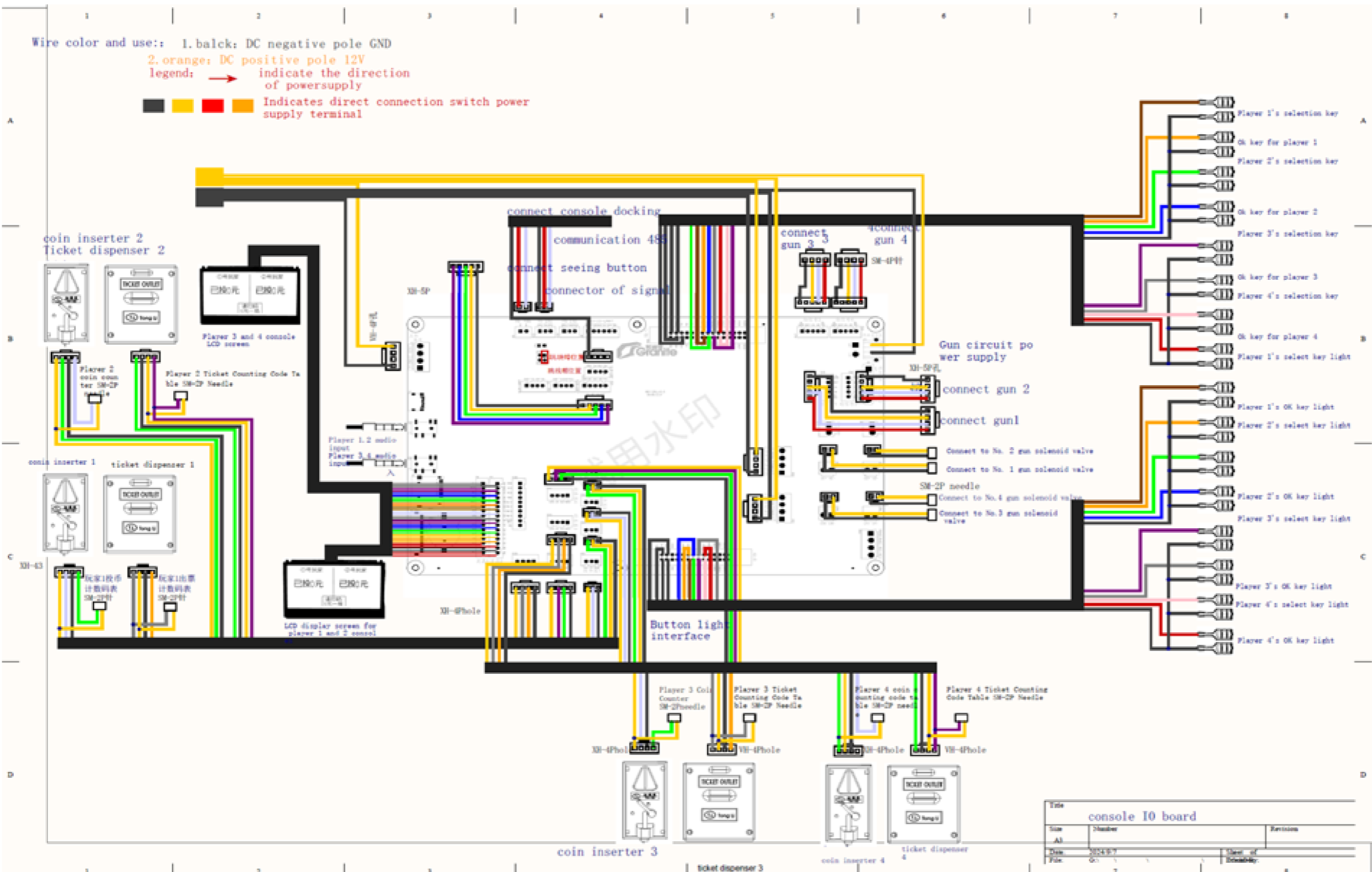

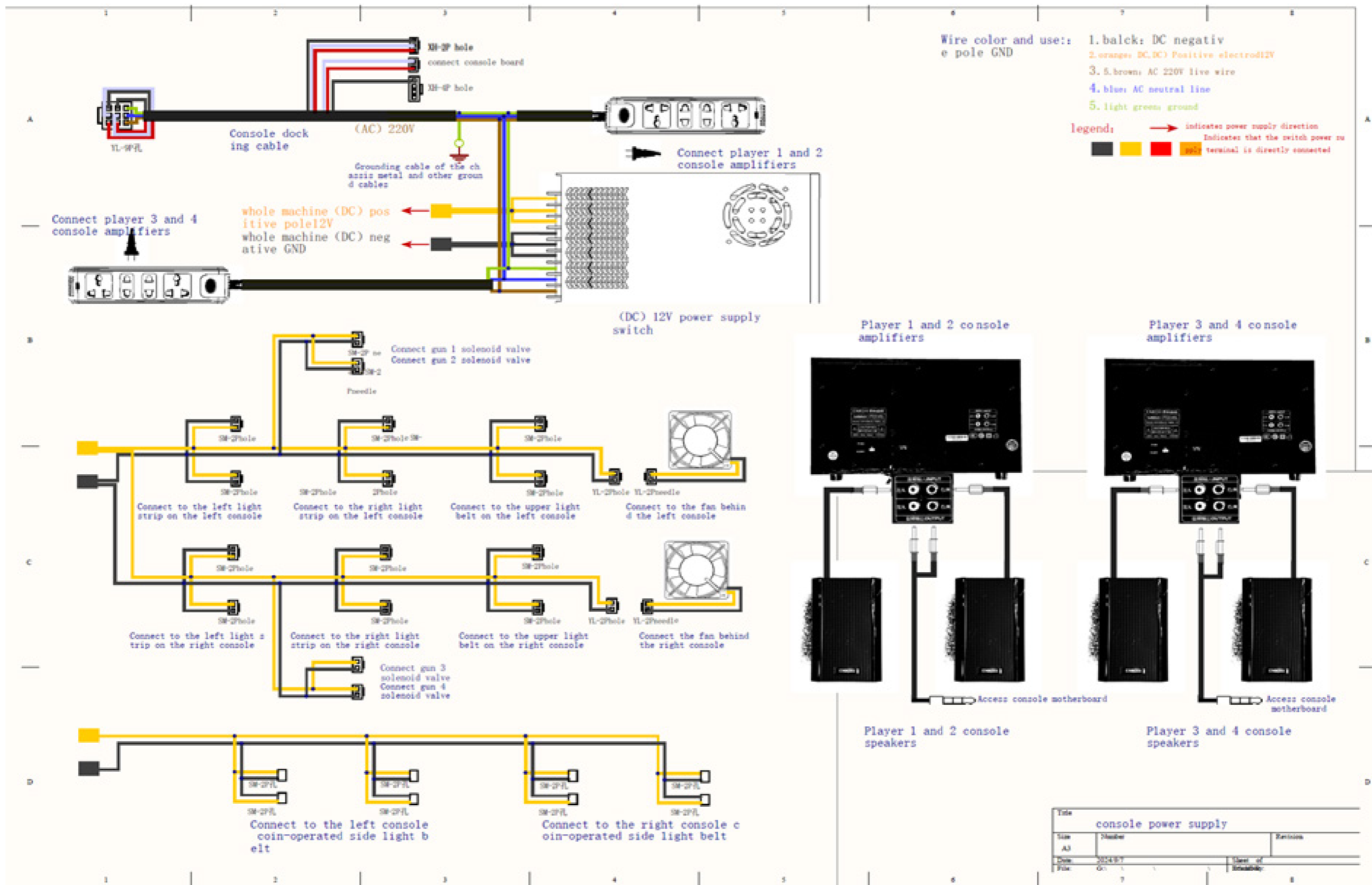

On target - Line Interface Allocation Diagram (V1.0)
Hardware Version Number: V3.0

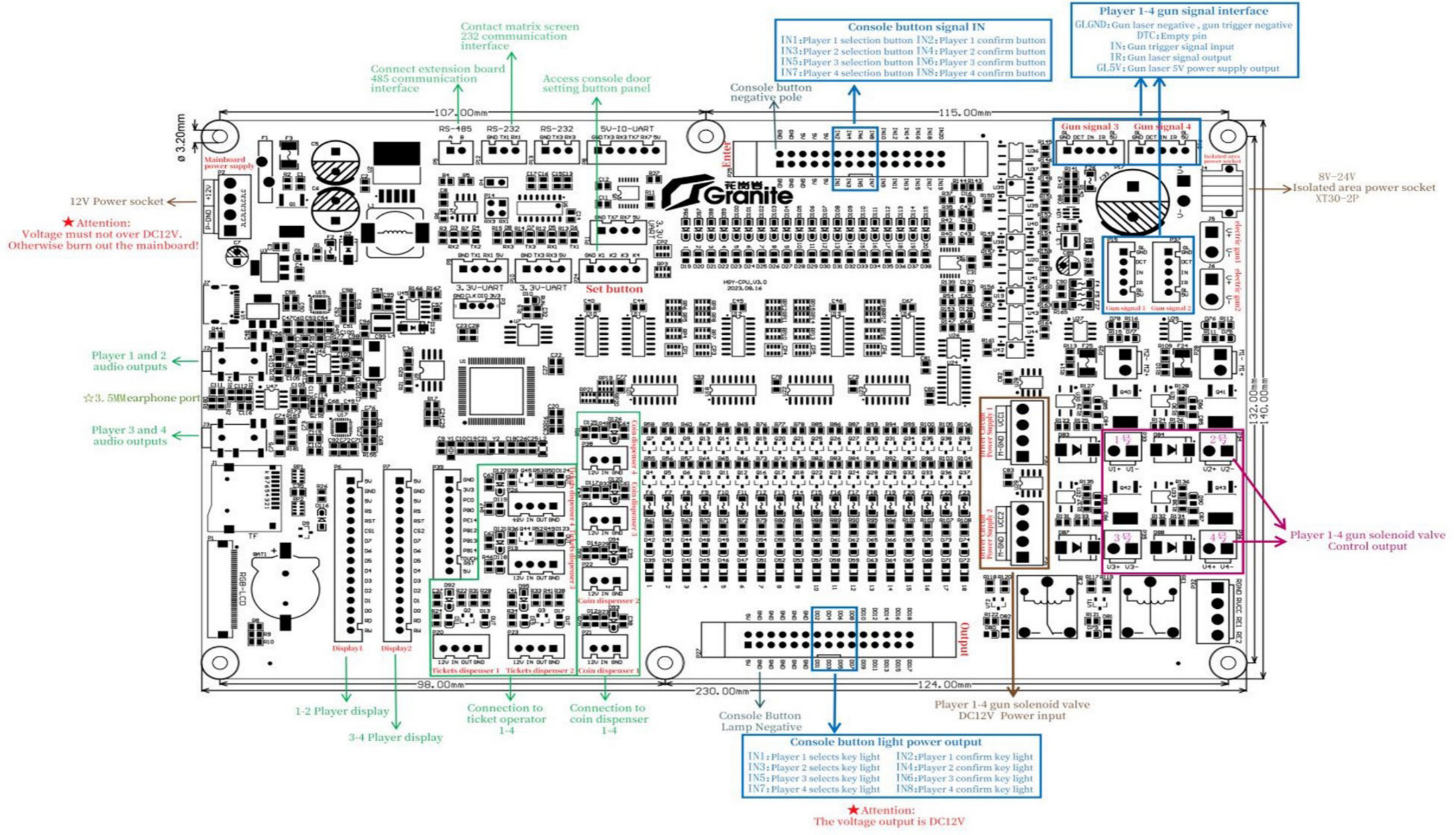

SPARES AND SERVICE CONTACT INFORMATION



amusements international

- SEGA TOTAL SOLUTIONS -

42 Barwell Business Park
Leatherhead Road,
Chessington,
Surrey,
KT9 2NY
United Kingdom

Parts: +44 (0) 2083918060
stssales@segaarcade.com

- TECHNICAL SUPPORT -

+44 (0) 2083918060
technical@segaarcade.com

- PLAY IT AMUSEMENTS -

870 Lively Blvd
Wood Dale,
IL,
602191
United States of America

Parts/Customer Service: +00 (1) 224 265 4287

Technical Support: +00 (1) 224 265 4283

PIA: support@playitamusements.com

